

# GT400

## Finished Units Assembly

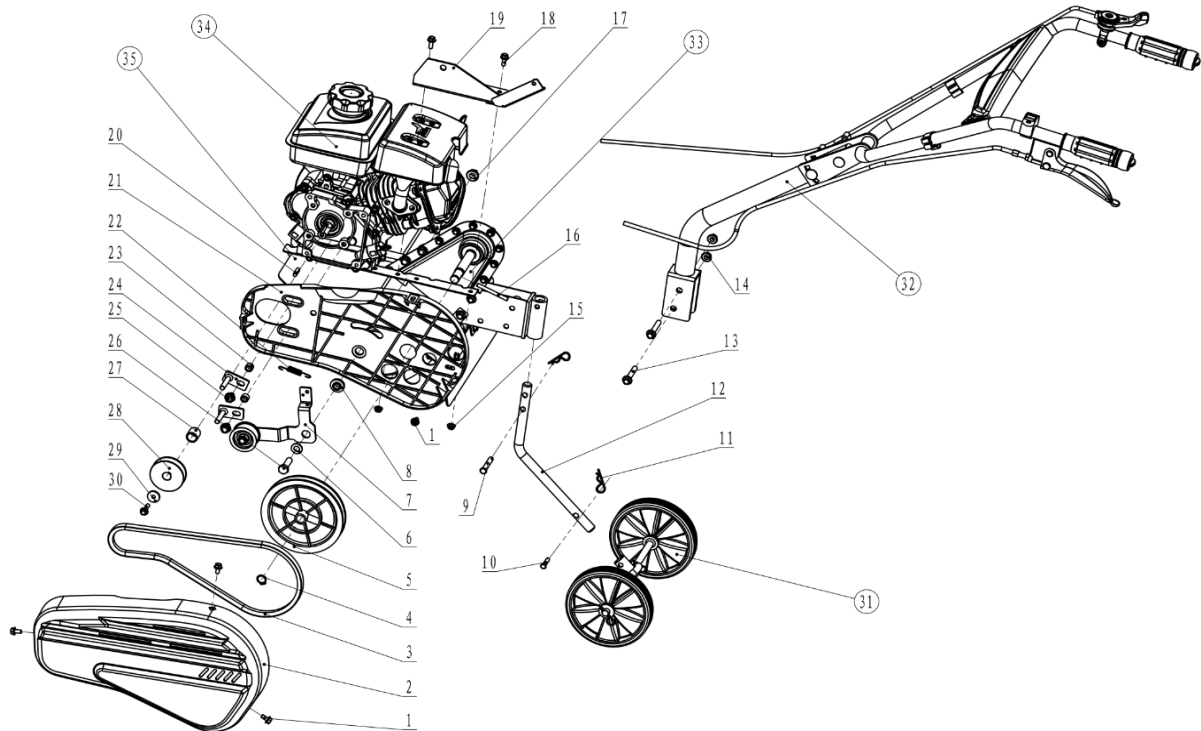

No.	Part Code	Parts Description	QTY
1	3037001007131	Hexagon flange bolt M6x12	4
2	W5301T0601I01	Belt Cover	1
3	W2001T0001000	Tooth type V Belt	1
4	3037005009002	Circlips for shaft	1
5	W2201T0601000	Follower Pulley	1
6	3037005019021	Flat Washer	1
7	W2400T0601000	Tensioning wheel assembly	1
8	W2302T0603000	Belt tensioning bushing	1
9	3037007002025	Axis Pin 8x35	1
10	3037007002022	Axis Pin 6x30	1
11	3037007008003	Locking Pin	2
12	W3003T0601000	Resistance	1
13	3037001008055	Hexagon Flange Bolt M8x50	2
14	3037004007006	Hexagon Lock Nut M8	2
15	3037004016015	Tooth Nut M6	2
16	3037007001017	Cylindrical Pin	1
17	3037004016017	Tooth Nut M10	1
18	3037001007133	Hexagon Flange M6x10	2
19	W5302T0601000	Tensioning Wheel Bracket	1
20	3037008001046	Flat Key	1
21	W5303T0601000	Cover Baseboard	1
22	W2403T0601000	Reset Tension Spring	1
23	W2302T0601000	Belt Pressing Bush	2
24	W5305T0601000	Belt Pressing	2
25	3037001007080	Hexagon Flange Bolt M8x12	2
26	3037001003118	Hexagon Flange Bolt M10x35	1
27	W2302T0602000	Belt Pully Bush	1
28	W2101T0601000	Driving Pulley	1
29	G904106000010	Driving Pulley Gasket	1
30	3037001007041	Hexagon Flange Bolt M6x20	1

# Handle Operation System

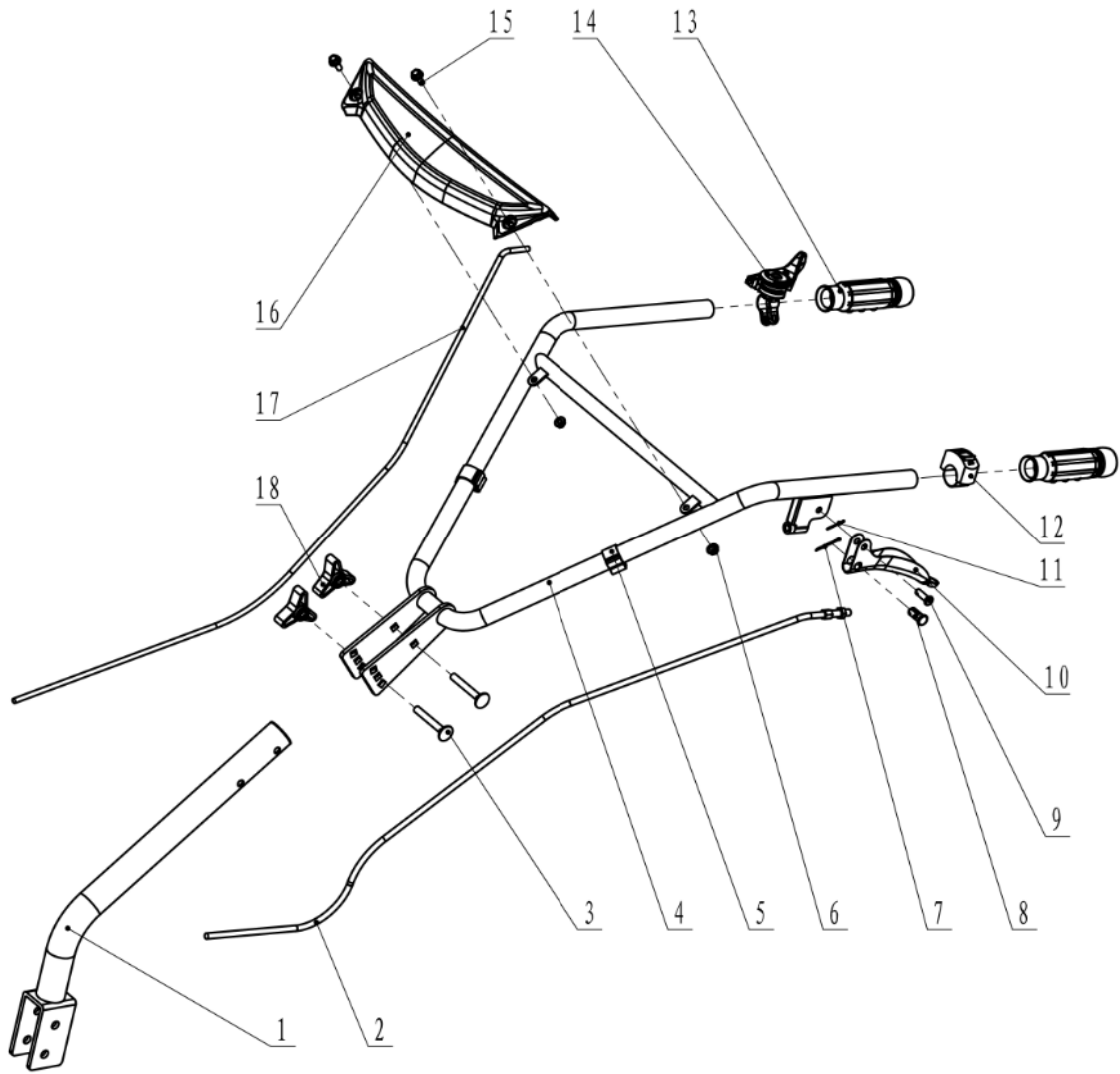

SN	Part Code	Parts Description	QTY
1	W4008T0601000	Handle Seat	1
2	W4402T0600010	Clutch Cable	1
3	3037001024001	Round Head Bolt M8x10	2
4	W4108T0601000	Handle Frame	1
5	W4503T0000000	Clip	2
6	3037004016015	Hexagon Flange Tooth Nut M6	2
7	3037007003005	Cotter Pin	1
8	3037011020001	Bracing Wire Joint	1
9	3037007002014	Axia Pin	1
10	W4104T0000H01	Clutch Handle	1
11	3037007003003	Cotter Pin	1
12	W4405T0005000	Engine Switch assy	1
13	W4504T0000000	Handle Grips	2
14	W4106T0003000	Gas Switch	1
15	3037001007133	Hexagon Flange Bolt M6x16	2
16	3037001007133	Cover for Handle Frame	1
17	W4403T0003000	Gas Cable	1
18	W4005T0601000	Handle Frame Locking Grip	1
19	3037005027002	*ΣΥΝΔΙΑΖΕΤΑΙ ΜΕ ΤΟ Νο. 18	2
20	G9006080000010		1

# Engine and Fender

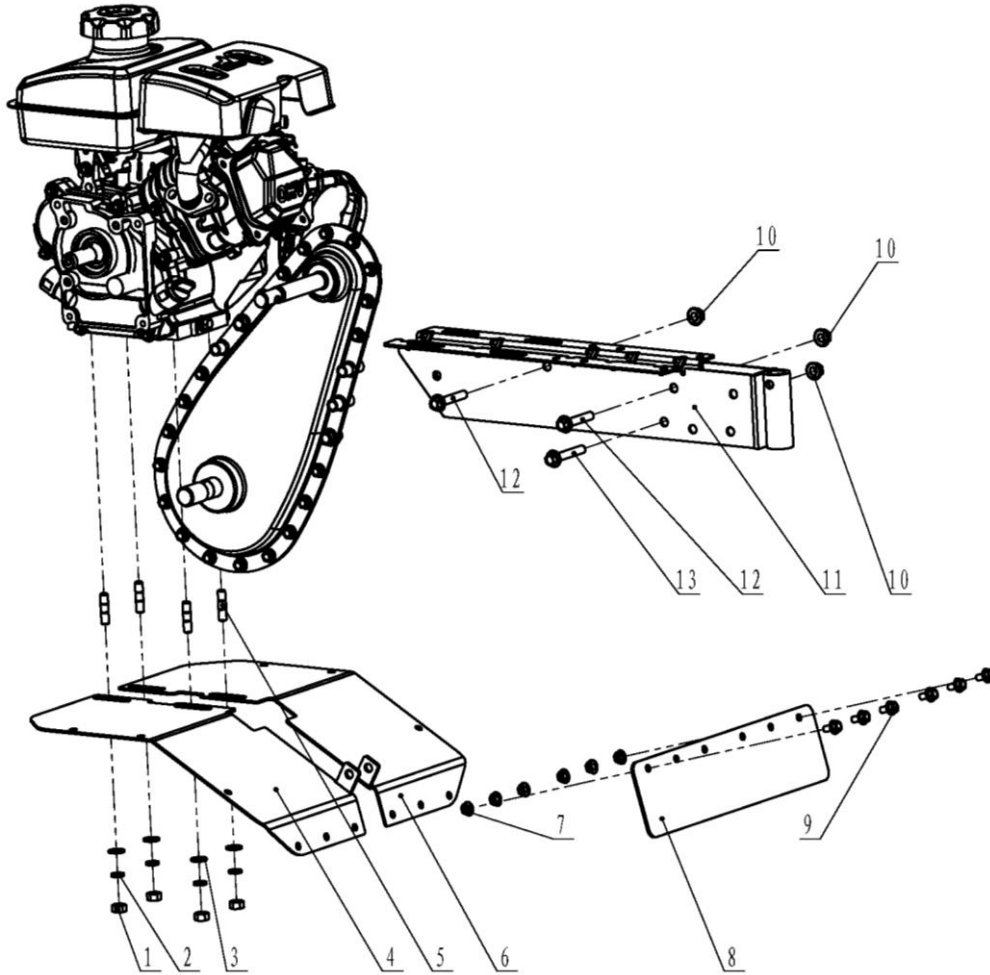

SN	Part Code	Parts Description	QTY
1	3037004001038	Hexagon Nut M8	4
2	3037005004036	Spring Washer M8	4
3	3037005019020	Flat Washer	4
4	W5003T0601000	Left Fender	1
5	G910308034010	Stud	4
6	W5004T0601000	Right Fender	1
7	3037004016015	Hexagon Flange Tooth Nut M6	6
8	W5001T0601000	Fender Rubber	1
9	3037001007131	Hexagon Flange Bolt M6x12	6
10	3037004007006	Hexagon Locking Nut M8	3
11	W3101T0602H01	Engine Tray	1
12	3037001008043	Hexagon Flange Bolt M8x45	2
13	3037001008055	Hexagon Flange Bolt M8x50	1

# Transmission Box

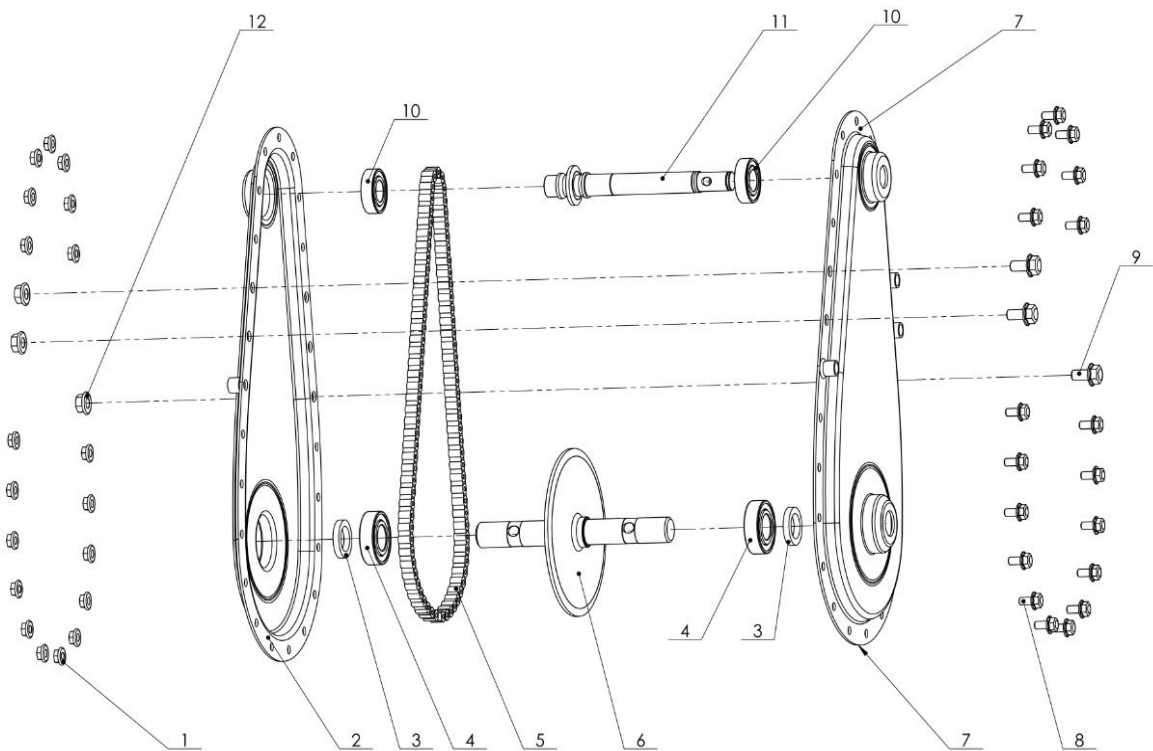

SN	Part Code	Parts Description	QTY
1	3037004016015	Hexagon Flange Tooth Nut M6	19
2	W1101T0602000	Gear Box-Right	1
3	3037010004001	Oil Seal	2
4	3037009001071	Deep groove ball bearing	2
5	W1222T0003000	Transmission Chain	1
6	W1221T0601000	Driven sprocket output shaft	1
7	W1101T0601000	Gear Box-Left	1
8	3037001007131	Hexagon Flange Bolt M6x12	19
9	3037001008047	Hexagon Flange Bolt M8x16	3
10	3037009001070	Deep groove ball bearing	2
11	W1201T0601000	Principal Axis	1
12	3037004016016	Hexagon Flange Nut M8	3

## Supporting Wheels

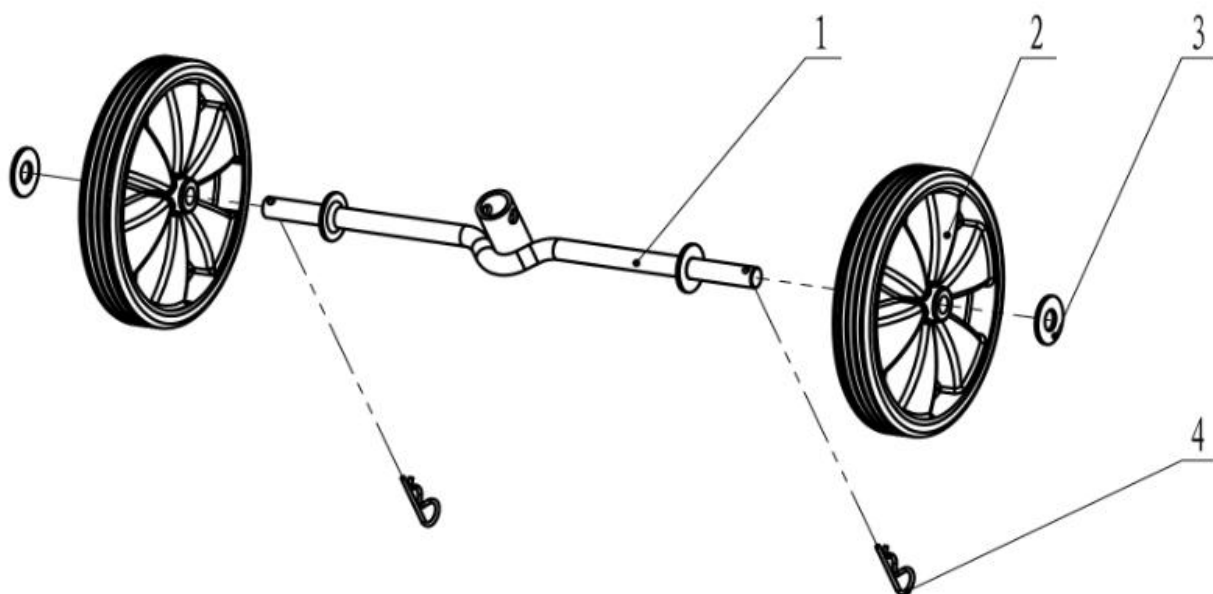

SN	Part Code	Parts Description	QTY
1	W6007T0601000	Axis	1
2	G3633G1401000	Front Wheel	2
3	3037005019024	Flat Washer	2
4	3037007008003	Locking Pin	2

## Blades Assembly

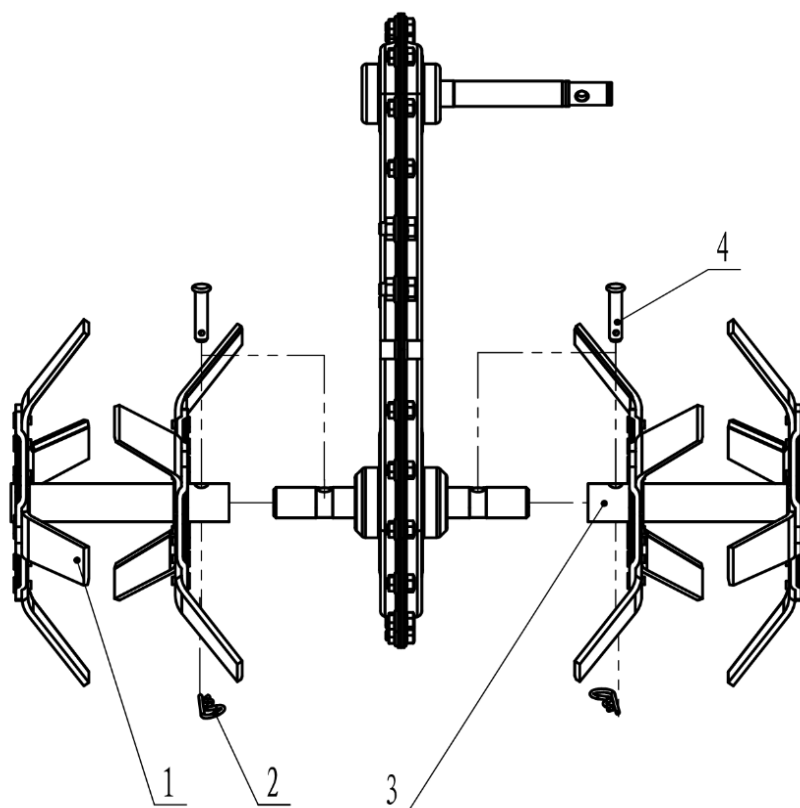

SN	Part Code	Parts Description	QTY
1	3037007002025	Axis Pin	2
2	W7916T0601000	Left Rotary Blades	1
3	3037007008003	Locking Pin	2
4	W7916T0602000	Right Rotary Blades	1