

(Note vulnerable properties: Refers to the degree of wear and tear in the day-to-day operation of the correct use of this part which according

机型Model:LC1P65FE

版本号: LC/LT - 2022 - A

曲轴箱 (CRANK CASE)

序号	零部件件号	Description	数量	易损属性
No.	Part No.		Reqd. QTY	CONSUMABLE GRADE
1	380020070-0001	Hexagon bolt with flange	4	C
2	120230118-0001	Cylinder head cover	1	C
3	120250045-0001	Gasket for cylinder head cover	1	A
4	140450060-0001	Valve rocker combination	2	B
5	140710013-0002	Plate, push rod guide	1	B
6	140380020-0001	Retainer, valve spring	2	B
7	140340039-0001	Inner spring of valve	2	B
8	270960014-0001	Spark plug	1	A
9	110810533-0001	Crankcase body	1	B
10	380180124-0001	Stud	2	C
11	380650335-0001	Oil seal	1	A
12	110860005-0001	Breath fin	1	A
13	110850019-0002	PACKING, BREATHER CHAMBER	1	A
14	110840027-0001	CAP, BREATHER CHAMBER	1	C

曲轴箱 (CRANK CASE)

序号	零部件件号	Description	数量	易损属性
No.	Part No.		Reqd. QTY	CONSUMABLE GRADE
15	380140167-0002	Hexagon bolt with flange	2	C
16	500550034-0001	Valve Kit	1	B
17	140670029-0001	Push rod	2	B
18	140690002-0001	Lifter, Valve	2	B
19	380140077-0005	Hexagon bolt with flange	1	C
20	380140209-0001	Hexagon bolt with flange	1	C
21	293030034-0001	Engine brake	1	B
22	381140687-0001	Tension spring	1	A
23	140400016-0001	Valve oil seal	2	B

曲轴箱盖 (CRANK CASE COVER)

序号	零部件件号	Description	数量	易损属性
No.	Part No.		Reqd. QTY	CONSUMABLE GRADE
1	380140103-0004	Hexagon bolt with flange	10	C
2	380650347-0001	Oil seal	1	A
3	110820117-0001	Crankcase cover	1	C
4	110690084-0004	Oil rule combination	1	B
5	380600241-0001	ocation pin	2	C
6	171750024-0001	Components of governor gear	1	B
7	380140167-0002	Hexagon bolt with flange	2	C
8	171630010-0002	Speed regulating arm	1	B
9	380450527-0001	Flat washer	1	C
10	380650338-0001	Oil seal	1	B
11	381350004-0001	Pin clip	1	A
12	380250002-0001	Square head set screw with flat point	1	C
13	171620033-0003	Speed regulating bracket	1	C
14	380370048-0001	Hexagon nut with flange	1	C
15	171600064-0001	Governing spring	1	A
16	171680099-0001	Throttle handle combination	1	B
17	380451013-0001	Flat washer	1	C

曲轴/活塞 (CRANKSHAFT/PISTON)

序号	零部件件号	Description	数量	易损属性
No.	Part No.		Reqd. QTY	CONSUMABLE GRADE
1	130070257-0001	Piston ring combination	1	A
2	130030301-0001	Piston	1	A
3	130060030-0001	Piston pin	1	B
4	380560055-0001	Steel cable baffle ring	2	B
5	130150099-0001	Connecting rod	1	B
6	130290413-0001	crankshaft	1	B
7	380450518-0001	Flat washer	1	C
8	140020117-0001	Camshaft assy	1	B
9	380450534-0001	Flat washer	1	C

起 动 器 (STARTER)

序号	零部件件号	Description	数量	易损属性
No.	Part No.		Reqd. QTY	CONSUMABLE GRADE
1	380370066-0001	Hexagon nut with flange	3	C
2	193490595-0001	Manual starting assembly	1	B
3	160210109-0003	Fan cover comp.	1	B
4	380850036-0001	Stay stud	2	C
5	380370051-0001	Hexagon nut with flange	1	C
6	380850035-0001	Stay stud	1	C
7	380140103-0004	Hexagon bolt with flange	1	C
8	270020604-0001	FLYWHEEL COMP	1	B
9	270920378-0002	COIL ASSY.,IGNNTION	1	A

化 油 器 (CARBURETOR)

序号	零部件件号	Description	数量	易损属性
No.	Part No.		Reqd. QTY	CONSUMABLE GRADE
1	170430148-0001	Carburetor gasket	1	A
2	170440126-0002	Heat insulating pad for carburetor	1	B
3	170450006-0001	Heat insulating plate for carburetor	1	B
4	170022519-0001	Carburetor	1	B
5	170430254-0001	Carburetor gasket	1	B
6	171590025-0001	Throttle rod	1	B

空 滤 器 (AIR CLEANER)

序号	零部件件号	Description	数量	易损属性
No.	Part No.		Reqd. QTY	CONSUMABLE GRADE
1	380741094-0002	Breather tube	1	A
2	180021086-0002	Air filter	1	B
3	180130347-0001	Air filter element	1	A
4	381000374-0001	Caulking	1	A
5	380370066-0001	Hexagon nut with flange	2	C

消声器 (MUFFLER)

序号	零部件件号	Description	数量	易损属性
No.	Part No.		Reqd. QTY	CONSUMABLE GRADE
1	380140209-0001	Hexagon bolt with flange	4	C
2	180960128-0001	Muffler guard shield	1	C
3	380140173-0002	Hexagon bolt with flange	2	C
4	180572097-0002	Muffler	1	B
5	180660077-0001	Muffler gasket	1	A
6	171470012-0001	Control components of choke valve	1	B
7	380140167-0002	Hexagon bolt with flange	2	C
8	171650040-0001	Choke valve pull rod	1	B
9	173090001-0001	Locker of choke valve pull rod	1	A

燃油箱 (FUEL TANK)

序号	零部件件号	Description	数量	易损属性
No.	Part No.		Reqd. QTY	CONSUMABLE GRADE
1	170870156-0002	Tank cover	1	B
2	170490374-0001	Tank	1	B
3	380020071-0001	Hexagon shaft shoulder bolt	2	C
4	170010017-0001	Fuel filter	1	A
5	380950190-0001	Pipe clip	2	B
6	380751281-0001	Oil tube	1	A

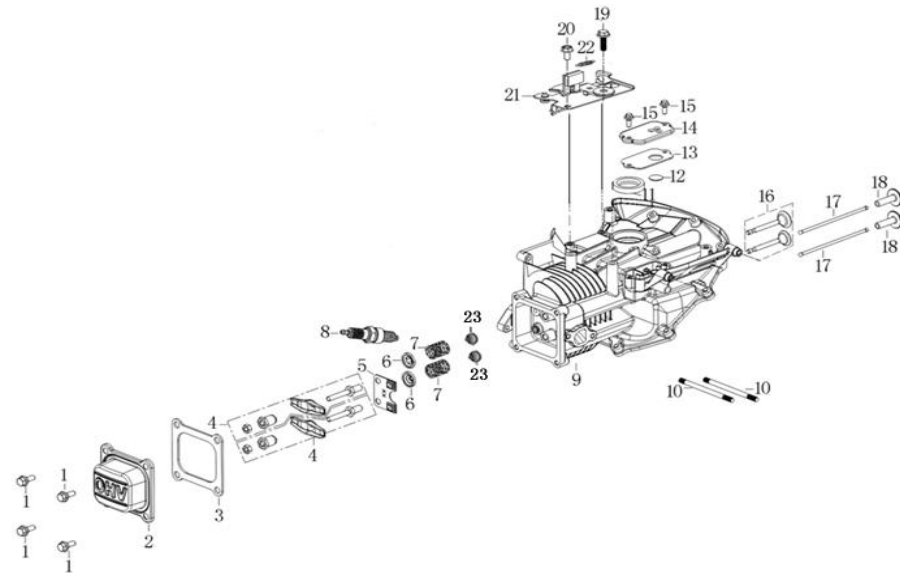

曲轴箱 (CRANK CASE)

序号 No.	零部件件号 Part No.	Description	规格状态	数量	易损属性
				Reqd. QTY	CONSUMABLE GRADE
1	380020070-0001	Hexagon bolt with flange	T370_M6×16.5(Φ8×3.5);镀蓝白锌Q16	4	C
2	120230118-0001	Cylinder head cover	T323;镀蓝白锌Q16	1	C
3	120250045-0001	Gasket for cylinder head cover	T323_软木橡胶板;	1	A
4	140450060-0001	Valve rocker combination	T323;	2	B
5	140710013-0002	Plate, push rod guide	T323;通机工程更改通知单号2017-0180_镀蓝白锌Q16	1	B
6	140380020-0001	Retainer, valve spring	T320_排气门用, 外径21.3, 总高5;	2	B
7	140340039-0001	Inner spring of valve	T322_7圈, 外径20.8, 高34.5;含Hg/Cr6/Pb/PBB/PBDE≤100ppm, Cd≤100ppm	2	B
8	270960014-0001	Spark plug	F7RTC_无干扰;	1	A
9	110810533-0001	Crankcase body	T323_可装挡油罩_增加5mm回油孔;	1	B
10	380180124-0001	Stud	T320_M6_L=91;镀蓝白锌Q16	2	C
11	380650335-0001	Oil seal	T320_d=25_D=38_b=7_丁晴橡胶;黑色	1	A
12	110860005-0001	Breath fin	T302;	1	A
13	110850019-0002	PACKING, BREATHER CHAMBER	T323;通机变更单号TJGGBG2020043	1	A
14	110840027-0001	CAP, BREATHER CHAMBER	T323;镀蓝白锌 Q16	1	C

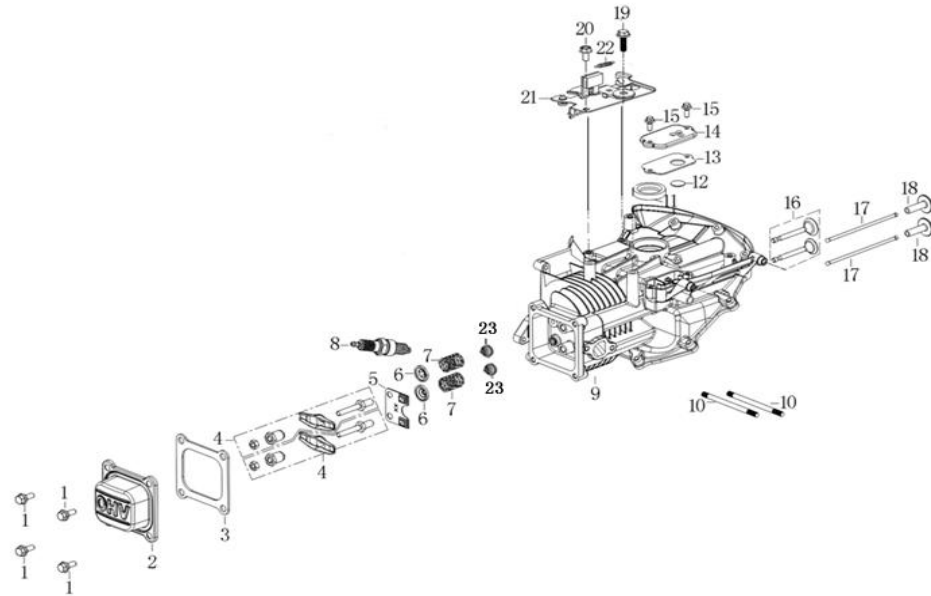

曲轴箱 (CRANK CASE)

序号	零部件件号	Description	规格状态	数量	易损属性
No.	Part No.			Reqd. QTY	CONSUMABLE GRADE
15	380140167-0002	Hexagon bolt with flange	GB/T 16674.1_M5_L=12; 镀蓝白锌Q16	2	C
16	500550034-0001	Valve Kit	T320_排气门不堆焊, 进气门磨光长度51±1;	1	B
17	140670029-0001	Push rod	T290; 含Hg/Cr6/Pb/PBB/PBDE≤1000ppm, Cd≤100ppm	2	B
18	140690002-0001	Lifter, Valve	T040; 含Hg/Cr6/Pb/PBB/PBDE≤1000ppm, Cd≤100ppm	2	B
19	380140077-0005	Hexagon bolt with flange	GB/T 5789_M6_L=20; 镀蓝白锌Q16	1	C
20	380140209-0001	Hexagon bolt with flange	GB/T 5789_M6_L=14; 镀蓝白锌Q16	1	C
21	293030034-0001	Engine brake	T323_5#_可拆卸摩擦块; 满足Reach要求	1	B
22	381140687-0001	Tension spring	T323_制动器弹簧_簧径1.8, 中径10.1, 20.5圈, 总长56; 满足REACH要求	1	A
23	140400016-0001	Valve oil seal	T05K; 含Hg/Cr6/Pb/PBB/PBDE≤1000ppm, Cd≤100ppm	2	B

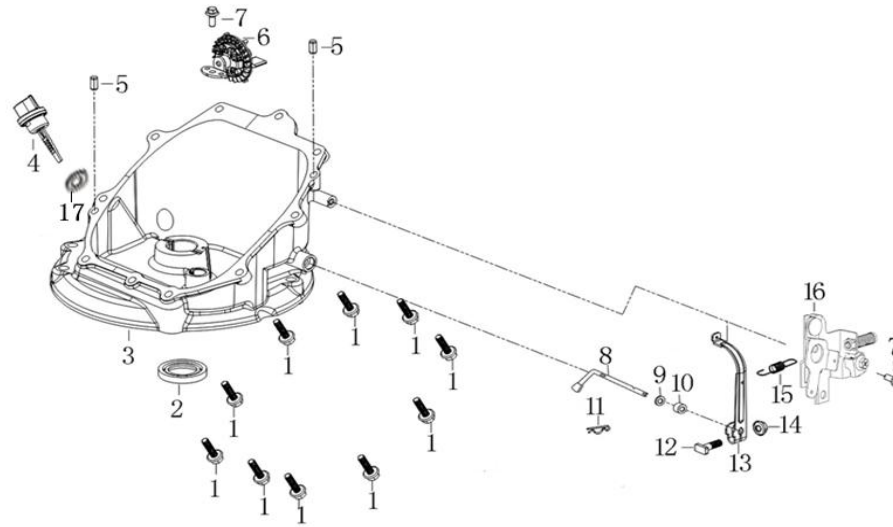

曲轴箱盖 (CRANK CASE COVER)

序号	零部件件号	Description	规格状态	数量	易损属性
No.	Part No.			Reqd. QTY	CONSUMABLE GRADE
1	380140103-0004	Hexagon bolt with flange	GB/T 5789_M6 L=25; 镀蓝白锌Q16	10	C
2	380650347-0001	Oil seal	T320_d=25_D=41.25_b=6_丙烯酸脂C11; 含Hg /Cr6/Pb/PPB/PRDE<1000ppm_Cd<100ppm	1	A
3	110820117-0001	Crankcase cover	T323;	1	C
4	110690084-0004	Oil rule combination	T323_机油尺_2#; 带密封圈, 加油管_满足PAHS 和REACH要求_加油管本色型6#080_机油尺木	1	B
5	380600241-0001	ocation pin	T323_d=6_L=16;	2	C
6	171750024-0001	Components of governor gear	T323;	1	B
7	380140167-0002	Hexagon bolt with flange	GB/T 16674.1_M5 L=12; 镀蓝白锌Q16	2	C
8	171630010-0002	Speed regulating arm	T320; 表面振动抛光	1	B
9	380450527-0001	Flat washer	T05K_T21_内径6_外径13_厚度1.65Mn; 氧化Q07	1	C
10	380650338-0001	Oil seal	T320_d=6_D=11_b=4;	1	B
11	381350004-0001	Pin clip	T040_调速臂用;	1	A
12	380250002-0001	Square head set screw with flat point	T040_M6 L=21(13mm); 调速支架固定	1	C
13	171620033-0003	Speed regulating bracket	T323; 带万头平端紧定螺钉/六角法三面螺母_不带防退齿_镀蓝白锌Q16	1	C
14	380370048-0001	Hexagon nut with flange	GB/T 6177.1_M6; 镀蓝白锌Q16	1	C
15	171600064-0001	Governing spring	T323_14圈, 簧径0.8, 长43;	1	A
16	171680099-0001	Throttle handle combination	T323_固定转速;	1	B
17	380451013-0001	Flat washer	T323_内径21_机油尺组合用;	1	C

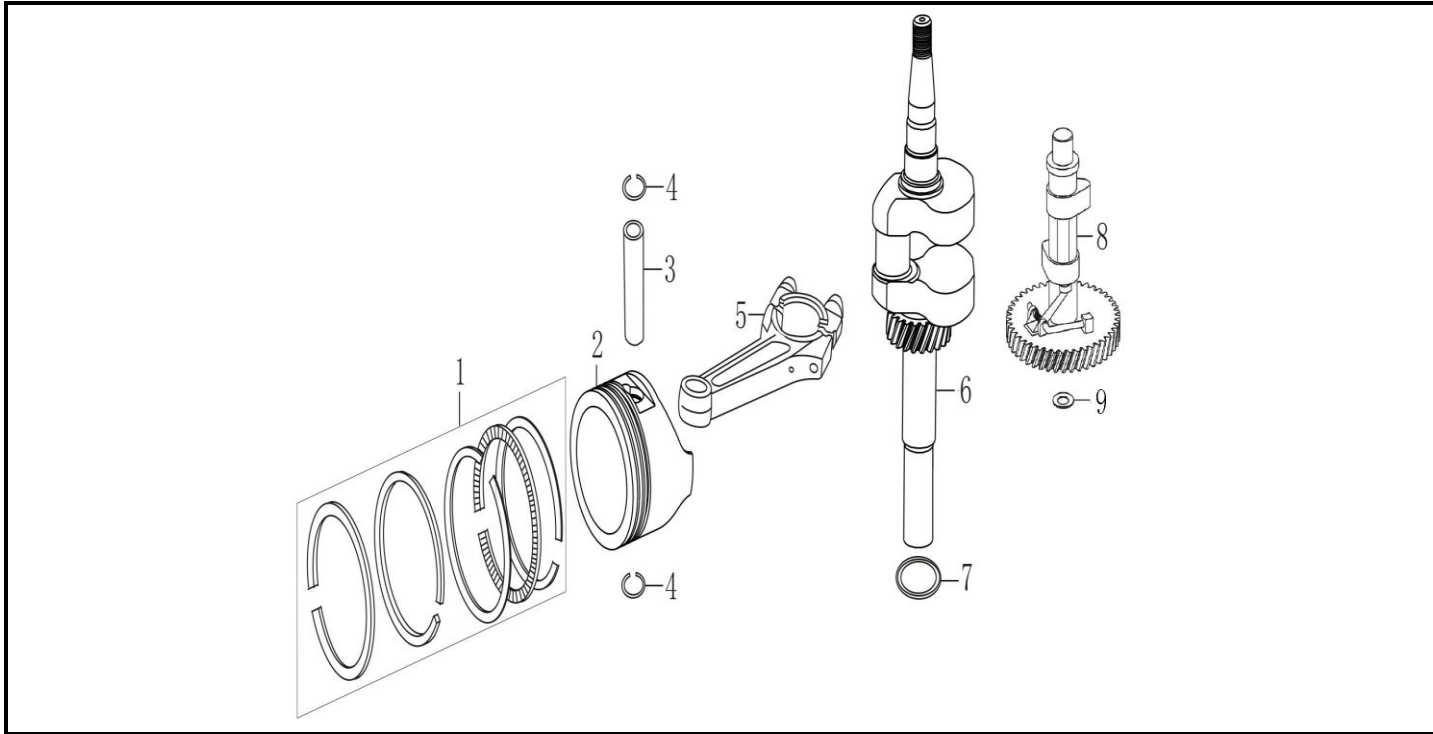

曲轴/活塞 (CRANKSHAFT/PISTON)

序号	零部件件号	Description	规格状态	数量	易损属性
No.	Part No.			Reqd. QTY	CONSUMABLE GRADE
1	130070257-0001	Piston ring combination	T323_一环, 二环厚1mm, 组合环厚2mm	1	A
2	130030301-0001	Piston	T323_2#, 一、二环厚1mm, 组合环厚2mm; 表面镀铬	1	A
3	130060030-0001	Piston pin	T030_φ13×47;	1	B
4	380560055-0001	Steel cable baffle ring	T030_活塞销挡圈;	2	B
5	130150099-0001	Connecting rod	T323_中心距72.5;	1	B
6	130290413-0001	crankshaft	T323_B轴_球墨铸铁_正时因为LC1P6 8FA;	1	B
7	380450518-0001	Flat washer	T320_T21_内径25.4_外径34_厚度1; 氧化007	1	C
8	140020117-0001	Camshaft assy	T323_塑料齿轮;	1	B
9	380450534-0001	Flat washer	T320_T21_内径14.2_外径20_厚度1; 抛光004	1	C

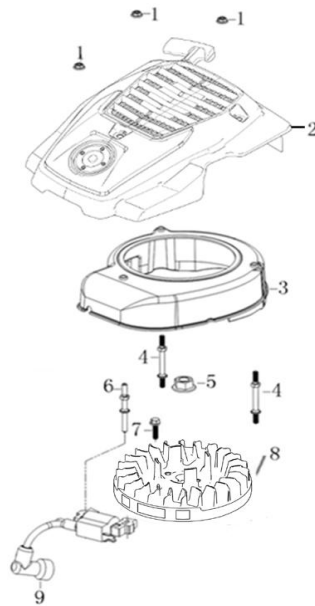

起动机 (STARTER)

序号	零部件件号	Description	规格状态	数量	易损属性
No.	Part No.			Reqd. QTY	CONSUMABLE GRADE
1	380370066-0001	Hexagon nut with flange	GB/T 6177.1 不带防滑齿 M6; 镀蓝白锌Q16	3	C
2	193490595-0001	Manual starting assembly	T323_32302款, 带32302款2#装饰罩; 满足REACH要求, 手柄满足REACH和PAHS要求_本色罩6#080_装饰罩本色	1	B
3	160210109-0003	Fan cover comp.	T323_2#, 通机规格变更号1J-GGBG 20180627000_本色罩6#080	1	B
4	380850036-0001	Stay stud	T323_M6_L=98_中间长度44, 圆盘头端螺纹中径加大5.35(0.05/0); 镀蓝白锌Q16	2	C
5	380370051-0001	Hexagon nut with flange	T040_M14×1.5; 镀蓝白锌Q16	1	C
6	380850035-0001	Stay stud	T327_M6_L=96_中间长度23.5, 圆盘头端螺纹中径加大5.35(0.05/0); 镀蓝白锌Q16	1	C
7	380140103-0004	Hexagon bolt with flange	GB/T 5789_M6_L=25; 镀蓝白锌Q16	1	C
8	270020604-0001	FLYWHEEL COMP	T323_2#, 铝飞轮, 带叶轮和3mm厚起动机杯;	1	B
9	270920378-0002	COIL ASSY., IGNITION	T320_14#_抗干扰, 带5kΩ金属屏蔽帽_高能量; 熄火线长230 PAHS认证	1	A

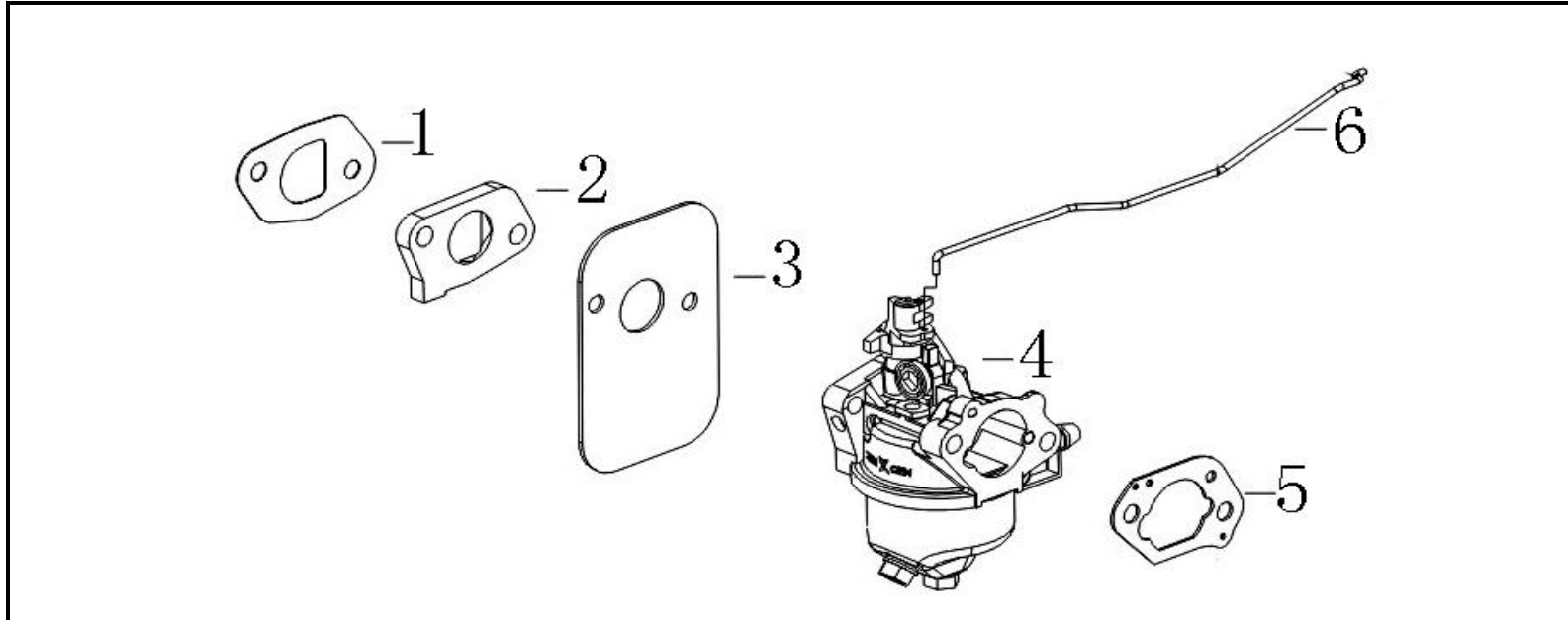

化油器 (CARBURETOR)

序号	零部件件号	Description	规格状态	数量	易损属性
No.	Part No.			Reqd. QTY	CONSUMABLE GRADE
1	170430148-0001	Carburetor gasket	T320_厚0.5_无石棉, BNS-JM101_进气管密封垫;	1	A
2	170440126-0002	Heat insulating pad for carburetor	T320_3#, 改安装孔; 通机规格变更号TJG GBG2020032	1	B
3	170450006-0001	Heat insulating plate for carburetor	T323_无石棉, BNS-GR001_厚1.2;	1	B
4	170022519-0001	Carburetor	T323_自动阻风门_32302款_欧V_防篡改, 金属阻风门轴, 反扭簧, 平移节气门扭簧挂孔_喉口直径 $\phi 12$ _平衡孔和主空	1	B
5	170430254-0001	Carburetor gasket	T323_无石棉, BNS-JM101_32302款_空滤器垫_平衡孔上移;	1	B
6	171590025-0001	Throttle rod	T323_长186, 杆径 $\phi 2$;	1	B

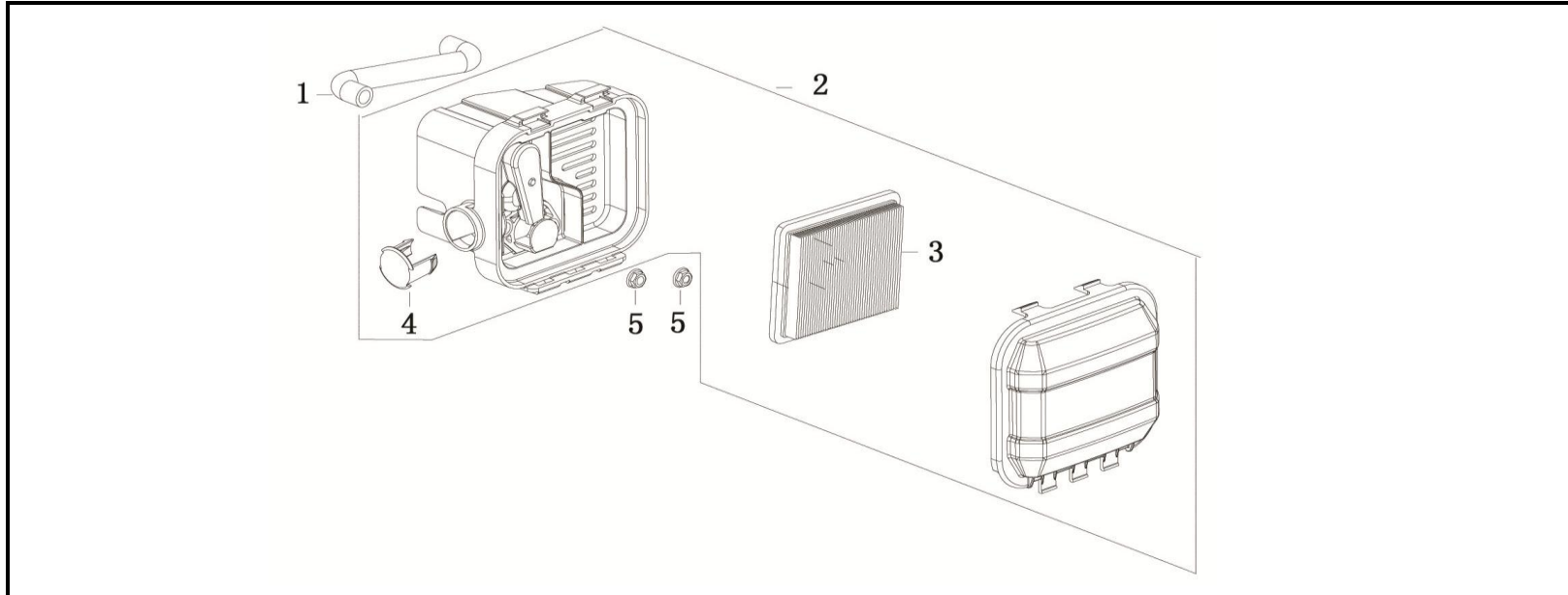

空滤器 (AIR CLEANER)

No.	Part No.			Reqd. QTY	CONSUMABLE GRADE
1	380741094-0002	Breather tube	T323_Φ11×Φ15_Z字型管_废气管;满足ROHS要求	1	A
2	180021086-0002	Air filter	T323_2#_贺氏纸滤芯_谐振腔口带堵头;打刻物料编码前9位180021065_通机规格变更单FM202102190423	1	B
3	180130347-0001	Air filter element	T321_HV6405滤纸_滤芯体;	1	A
4	381000374-0001	Caulking	T323_PP料_空滤器用;	1	A
5	380370066-0001	Hexagon nut with flange	GB/T 6177.1_不带防滑齿_M6;镀蓝白锌Q16	2	C

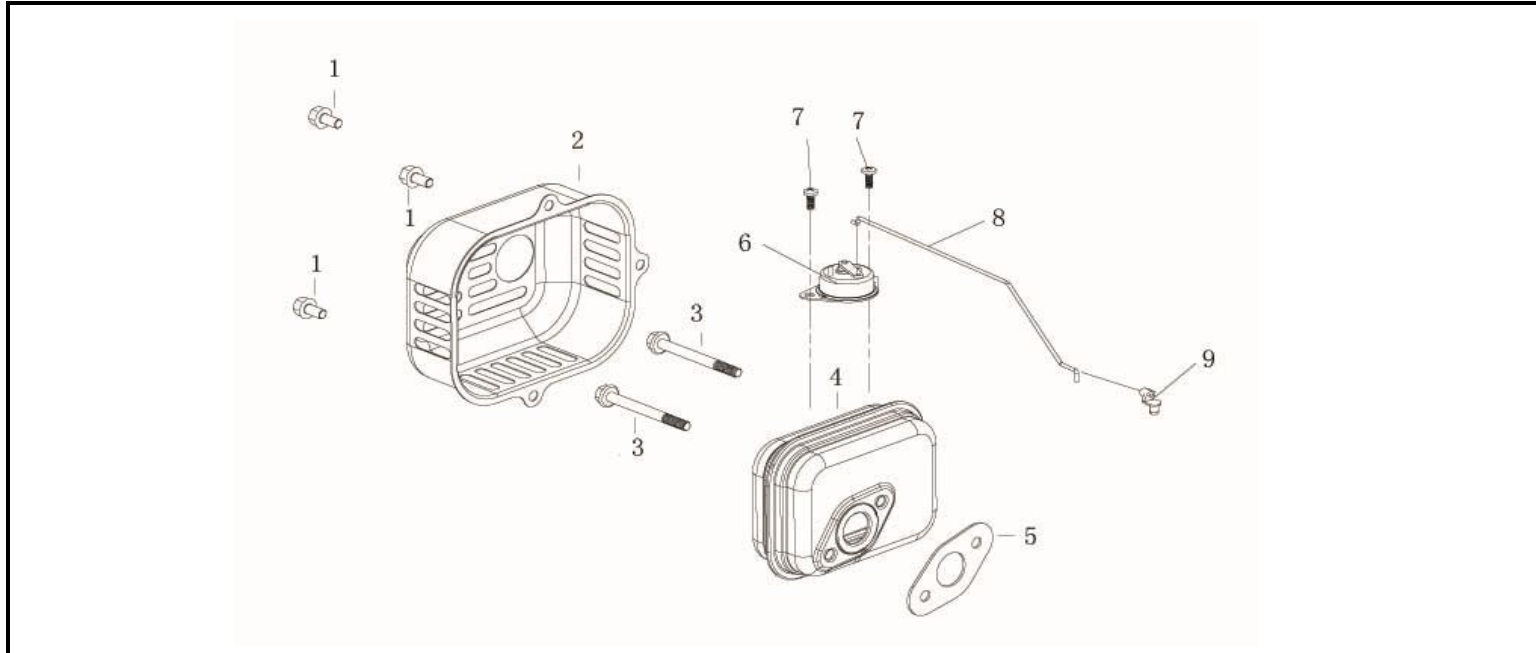

消声器 (MUFFLER)

序号	零部件件号	Description	规格状态	数量	易损属性
No.	Part No.			Reqd. QTY	CONSUMABLE GRADE
1	380140209-0001	Hexagon bolt with flange	GB/T 5789_M6_L=14; 镀蓝白锌Q16	4	C
2	180960128-0001	Muffler guard shield	T323; 喷塑(亚光黑)Q27	1	C
3	380140173-0002	Hexagon bolt with flange	GB/T 5789_M6_L=60; 镀蓝白锌Q16	2	C
4	180572097-0002	Muffler	T323_2#_带温度传感器状态; 通机规格 变更单FM202001160036	1	B
5	180660077-0001	Muffler gasket	T323_石墨;	1	A
6	171470012-0001	Control components of choke valve	T323_自动阻风门, 摇臂状态;	1	B
7	380140167-0002	Hexagon bolt with flange	GB/T 16674.1_M5_L=12; 镀蓝白锌Q16	2	C
8	171650040-0001	Choke valve pull rod	T323_自动阻风门状态_长拉杆, 长165.5 ; 镀蓝白锌Q16	1	B
9	173090001-0001	Locker of choke valve pull rob	T240_锁夹 I_电机用;	1	A

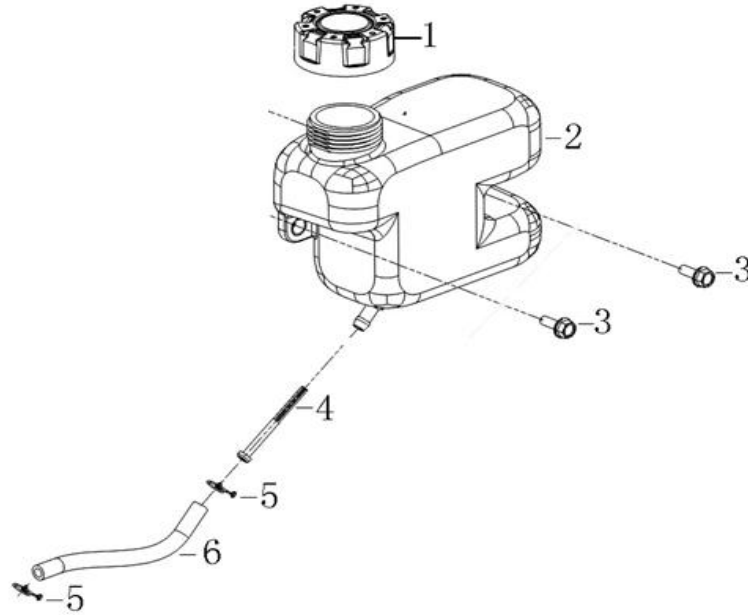

燃油箱 (FUEL TANK)

No.	Part No.			Reqd. QTY	CONSUMABLE GRADE
1	170870156-0002	Tank cover	T320_3#_丁腈橡胶密封垫+通气板;满足REACH要求	1	B
2	170490374-0001	Tank	T323_32302款1#;满足REACH要求	1	B
3	380020071-0001	Hexagon shaft shoulder bolt	T370_M6×15(Φ10×1.8);镀蓝白锌Q16	2	C
4	170010017-0001	Fuel filter	T350_250目;	1	A
5	380950190-0001	Pipe clip	T320_Φ10.5±0.5_油管卡圈;镀蓝白锌Q16	2	B
6	380751281-0001	Oil tube	T323_内径5.5_外径9.5_长135;满足ROHS要求	1	A