

机型Model: LC1P90F		成品编码 Code Number:T370002340- 15Q1554	版本号: LC/LT - 2018 - A	
汽缸头 (Cylinder Head)				
序号 No.	零部件件号 Part No.	Description	数量	易损属性
			Reqd. QTY	CONSUMABLE GRADE
1	120080436-0001	Cylinder head	1	B
2	120150164-0001	Gasket for cylinder head	1	A
3	380600116-0001	ocation pin	2	C
4	380180088-0001	Stud	2	C
5	180650074-0001	Outlet gasket	1	A
6	270960028-0002	Spark plug	1	A
7	160190014-0001	air deflector	1	C
8	380140335-0001	Hexagon bolt with flange	4	C
9	380140067-0003	Hexagon bolt with flange	1	C
10	120250028-0001	Gasket for cylinder head cc	1	A
11	120230195-0001	Cylinder head cover		C
12	380020070-0001	Hexagon shaft shoulder bolt	4	C
箱体 (Crankcase)				
序号 No.	零部件件号 Part No.	Description	数量	易损属性
			Reqd. QTY	CONSUMABLE GRADE
1	380740462-0002	Breather tube	1	A
2	381350004-0001	Pin clip	1	A
3	380650339-0001	Oil seal	1	B
4	380450559-0001	Flat washer	1	C
5	171630032-0001	Speed regulating arm	1	B
6	110830033-0001	Crankcase cover gasket	1	A
7	380630026-0001	Bearing	2	B
8	380840443-0001	Seal ring	1	A
9	380630141-0002	Bearing	1	B
10	110810026-0001	Crankcase body	1	B
11	140250006-0001	Leaf valve	1	A
12	380140067-0003	Hexagon bolt with flange	3	C
箱体 (Crankcase)				
序号 No.	零部件件号 Part No.	Description	数量	易损属性
			Reqd. QTY	CONSUMABLE GRADE
13	110850004-0001	PACKING, BREATHER CHAMBER	1	A
14	110840005-0001	CAP, BREATHER CHAMBER	1	C
15	380650337-0001	Oil seal	1	B
16	380600122-0001	ocation pin	2	C
17	380940346-0001	Cable cleat	1	A
曲轴箱盖 (Crankcase Cover)				
序号	零部件件号	Description	数量	易损属性

No.	Part No.	Description	Reqd. QTY	CONSUMABLE GRADE
1	110820021-0001	Crankcase cover	1	C
2	171750021-0001	Components of governor gear	1	B
3	380630141-0002	Bearing	1	B
4	150290022-0001	Engine oil Strainer	1	A
5	120530002-0001	Pressing plate for oil groc	1	C
6	150340013-0001	Cover,Oil Strainer	1	C
7	380140103-0004	Hexagon bolt with flange	1	C
8	110260026-0001	Sealing plug screw	1	C
9	380600123-0001	ocation pin	2	C
10	150570003-0001	Engine oil return block	1	A
11	380140013-0005	Hexagon bolt with flange	3	C
12	150040019-0001	Oil pump cover	1	C
13	380840813-0001	Seal ring	1	A
14	150010073-0001	Components of oil pump	1	B

曲轴箱盖 (Crankcase Cover)

序号 No.	零部件件号 Part No.	Description	数量	易损属性
			Reqd. QTY	CONSUMABLE GRADE
15	380450444-0002	Flat washer	1	C
16	380140100-0003	Hexagon bolt with flange	1	C
17	110690091-0001	Oil rule combination	1	B
18	380650337-0001	Oil seal	1	B
19	380140447-0001	Hexagon bolt with flange	7	C

曲轴 (Crankshaft)

序号 No.	零部件件号 Part No.	Description	数量	易损属性
			Reqd. QTY	CONSUMABLE GRADE
1	130070161-0001	Piston ring combination	1	A
2	130030165-0001	Piston	1	A
3	130060034-0001	Piston pin	1	B
4	380560057-0001	Steel cable baffle ring	2	B
5	130150048-0001	Connecting rod	1	B
6	130290102-0001	crankshaft	1	B
7	130450033-0001	Balancing shaft	1	B
8	130450034-0001	Balancing shaft	1	B
9	380450560-0001	Flat washer	2	B

配气机构 (Valve)

序号 No.	零部件件号 Part No.	Description	数量	易损属性
			Reqd. QTY	CONSUMABLE GRADE
1	140450041-0002	Valve rocker combination	2	B
2	500550039-0001	Valve Kit	1	B
3	140360010-0001	Seat, valve spring	2	B
4	140400012-0001	Valve oil seal	2	B

5	140340025-0001	Inner spring of valve	2	B
6	140380021-0001	Retainer, valve spring	2	B
7	140390015-0001	Valve locker	4	B
8	140320002-0001	Valve adjustment cap	2	B
9	140690004-0001	Lifter, Valve	2	B
10	140670030-0001	Push rod	2	B
11	140710011-0001	Plate, push rod guide	1	B
12	140020195-0001	Camshaft assy	1	B

挡风罩 (Blower Housing)

序号 No.	零部件件号 Part No.	Description	数量	易损属性
			Reqd. QTY	CONSUMABLE GRADE
1	160210016-0001	Fan cover comp.	1	B
2	380020070-0001	Hexagon shaft shoulder bolt	4	C
3	380420031-0001	Clip nut	3	C
4	195360007-0001	Starter outer cover	1	B
5	380140039-0003	Hexagon bolt with flange	3	C

化油器 (Carburetor)

序号 No.	零部件件号 Part No.	Description	数量	易损属性
			Reqd. QTY	CONSUMABLE GRADE
1	170022053-0001	Carburetor	1	B
2	170430173-0001	Carburetor gasket	1	A
3	170430099-0001	Carburetor gasket	2	A
4	160190013-0001	air deflector	1	C
5	170440053-0001	Heat insulating pad for carb	1	B
6	170430101-0001	Carburetor gasket	1	A
7	380140067-0003	Hexagon bolt with flange	1	C
8	380960120-0004	Clip combination	2	A
9	170010018-0001	Fuel filter	1	A
10	380750431-0001	Oil tube	1	A

飞轮 (Flywheel)

序号 No.	零部件件号 Part No.	Description	数量	易损属性
			Reqd. QTY	CONSUMABLE GRADE
1	380370050-0001	Hexagon nut with flange	1	C
2	193590013-0001	Starting disc	1	C
3	160180037-0001	Impeller	1	B
4	270020229-0001	FLYWHEEL COMP	1	B
5	380140100-0003	Hexagon bolt with flange	4	C
6	270190043-0001	Components of charging curr	1	A
7	270920251-0004	COIL ASSY., IGNNTION	1	A
8	271280141-0001	Connecting wire	1	A
9	380140209-0001	Hexagon bolt with flange	2	C
10	270880220-0001	RectifierVariable voltage r	1	A

11	380140364-0001	Hexagon bolt with flange	2	C
12	270360138-0001	Components of starting motc	1	B
13	380930113-0001	Location wire nail	1	A
调速机构 (Governor)				
序号 No.	零部件件号 Part No.	Description	数量	易损属性
			Reqd. QTY	CONSUMABLE GRADE
1	380140013-0005	Hexagon bolt with flange	1	C
2	171680158-0001	Throttle handle combination	1	B
3	380140209-0001	Hexagon bolt with flange	2	C
4	171600020-0001	Governing spring	1	A
5	380370066-0001	Hexagon nut with flange	1	C
6	171620013-0003	Speed regulating bracket	1	C
7	380250002-0001	Square head set screw with	1	C
8	171590013-0001	Throttle rod	1	B
9	171490002-0001	Choke valve bar	1	B
10	380020071-0001	Hexagon shaft shoulder bolt	1	C
11	171480013-0001	Choke valve bracket	1	C
12	171650003-0001	Choke valve pull rod	1	B
空滤器 (Air Cleaner)				
序号 No.	零部件件号 Part No.	Description	数量	易损属性
			Reqd. QTY	CONSUMABLE GRADE
1	180100056-T370	Air filter element combinat	1	A
2	180070092-T370	Air filter casing cover	1	B
3	181950002-0001	Bolt handle	2	B
4	180280150-T370	Air filter seat	1	B
5	180021007-0001	Air filter	1	B
6	380370066-0001	Hexagon nut with flange	2	C
7	380140100-0003	Hexagon bolt with flange	1	C

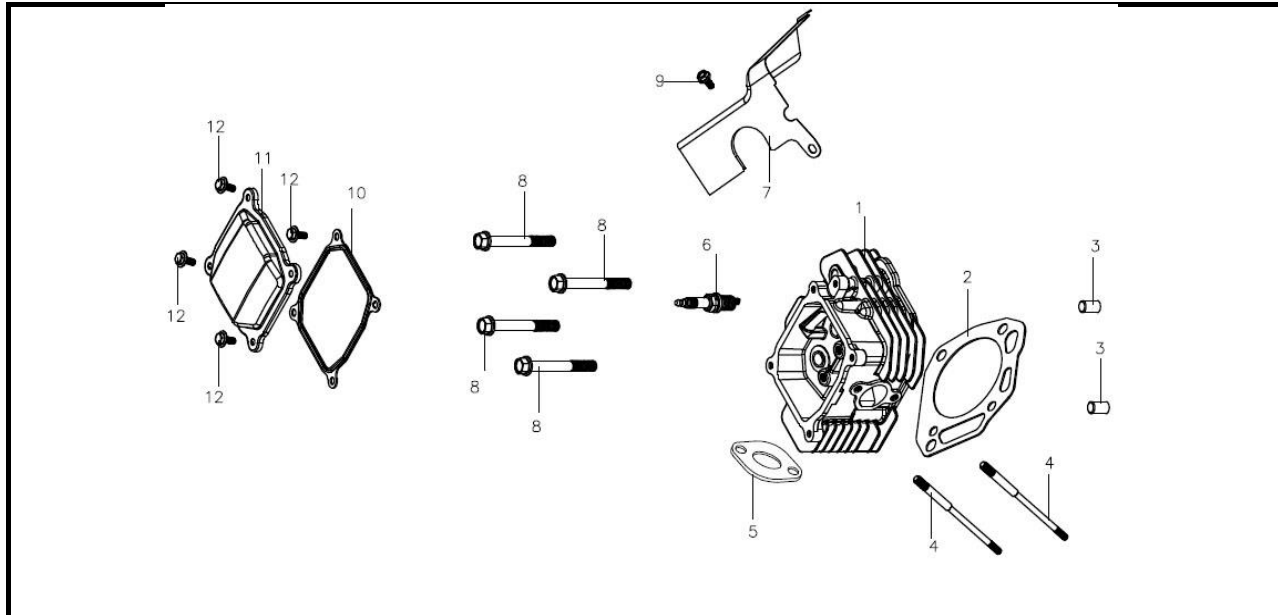

汽缸头 (Cylinder Head)

序号 No.	零部件件号 Part No.	Description	数量	易损属性
			Reqd. QTY	CONSUMABLE GRADE
1	120080436-0001	Cylinder head	1	B
2	120150164-0001	Gasket for cylinder head	1	A
3	380600116-0001	ocation pin	2	C
4	380180088-0001	Stud	2	C
5	180650074-0001	Outlet gasket	1	A
6	270960028-0002	Spark plug	1	A
7	160190014-0001	air deflector	1	C
8	380140335-0001	Hexagon bolt with flange	4	C
9	380140067-0003	Hexagon bolt with flange	1	C
10	120250028-0001	Gasket for cylinder head cover	1	A
11	120230195-0001	Cylinder head cover	1	C
12	380020070-0001	Hexagon shaft shoulder bolt	4	C

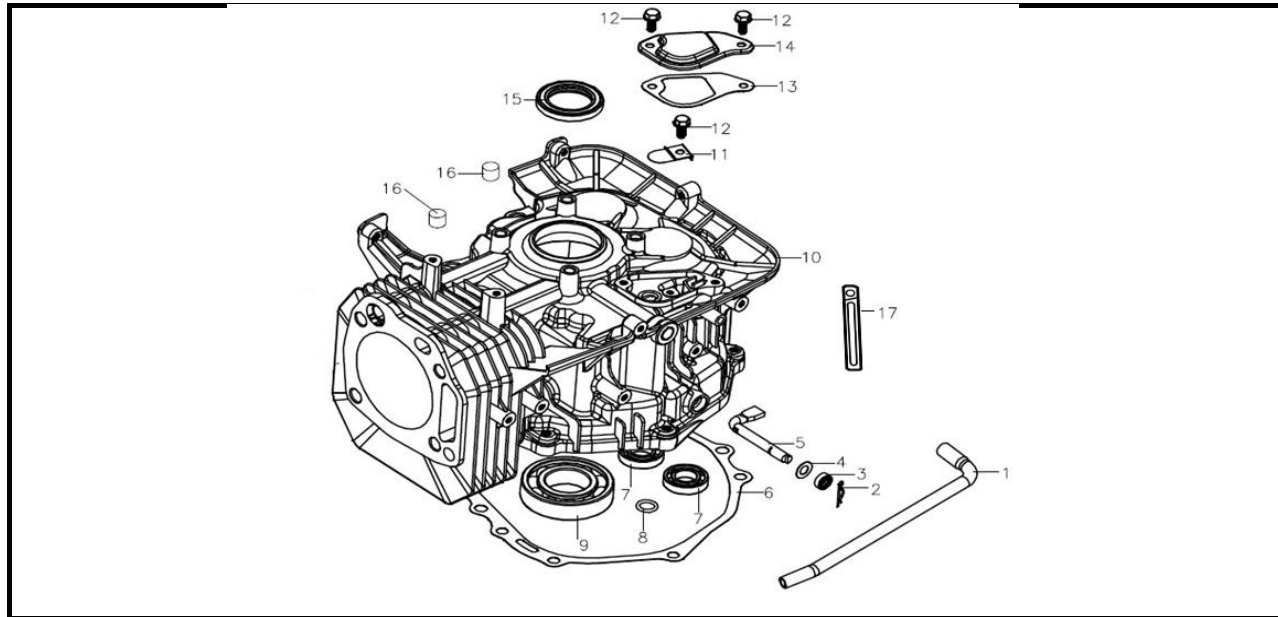

箱体 (Crankcase)

序号 No.	零部件件号 Part No.	Description	数量	易损属性
			Reqd. QTY	CONSUMABLE GRADE
1	380740462-0002	Breather tube	1	A
2	381350004-0001	Pin clip	1	A
3	380650339-0001	Oil seal	1	B
4	380450559-0001	Flat washer	1	C
5	171630032-0001	Speed regulating arm	1	B
6	110830033-0001	Crankcase cover gasket	1	A
7	380630026-0001	Bearing	2	B
8	380840443-0001	Seal ring	1	A
9	380630141-0002	Bearing	1	B
10	110810026-0001	Crankcase body	1	B
11	140250006-0001	Leaf valve	1	A
12	380140067-0003	Hexagon bolt with flange	3	C

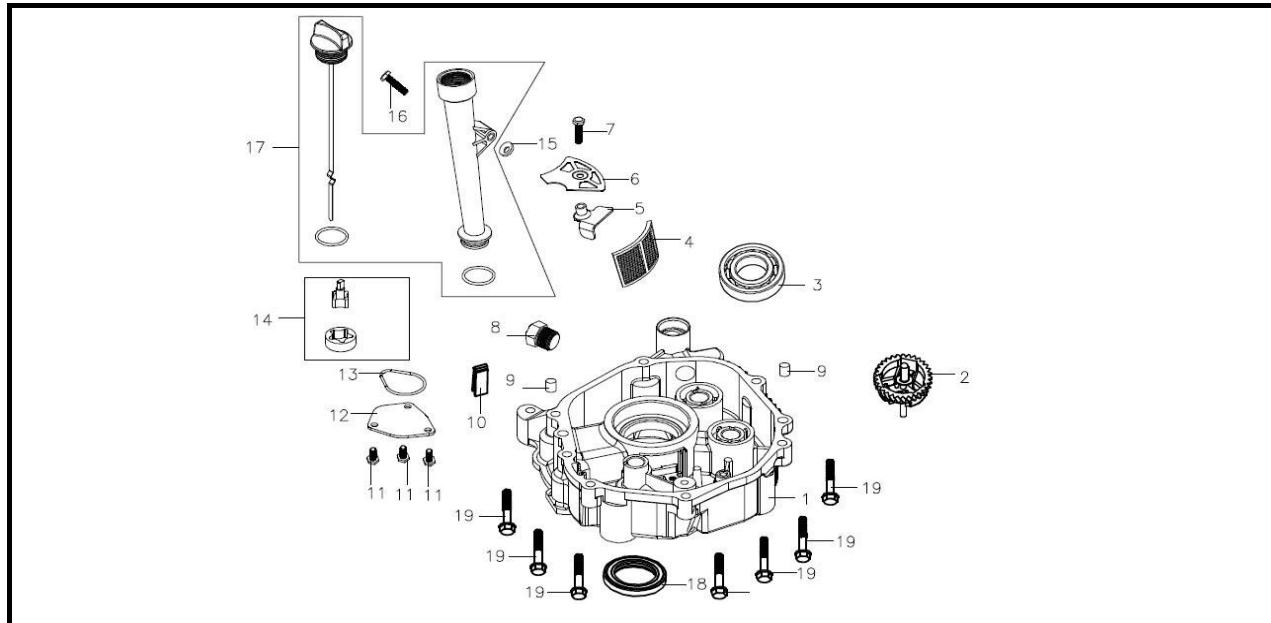

曲轴箱盖 (Crankcase Cover)

序号 No.	零部件号 Part No.	Description	数量	易损属性
			Reqd. QTY	CONSUMABLE GRADE
1	110820021-0001	Crankcase cover	1	C
2	171750021-0001	Components of governor gear	1	B
3	380630141-0002	Bearing	1	B
4	150290022-0001	Engine oil Strainer	1	A
5	120530002-0001	Pressing plate for oil groove	1	C
6	150340013-0001	Cover, Oil Strainer	1	C
7	380140103-0004	Hexagon bolt with flange	1	C
8	110260026-0001	Sealing plug screw	1	C
9	380600123-0001	ocation pin	2	C
10	150570003-0001	Engine oil return block	1	A
11	380140013-0005	Hexagon bolt with flange	3	C
12	150040019-0001	Oil pump cover	1	C
13	380840813-0001	Seal ring	1	A
14	150010073-0001	Components of oil pump	1	B

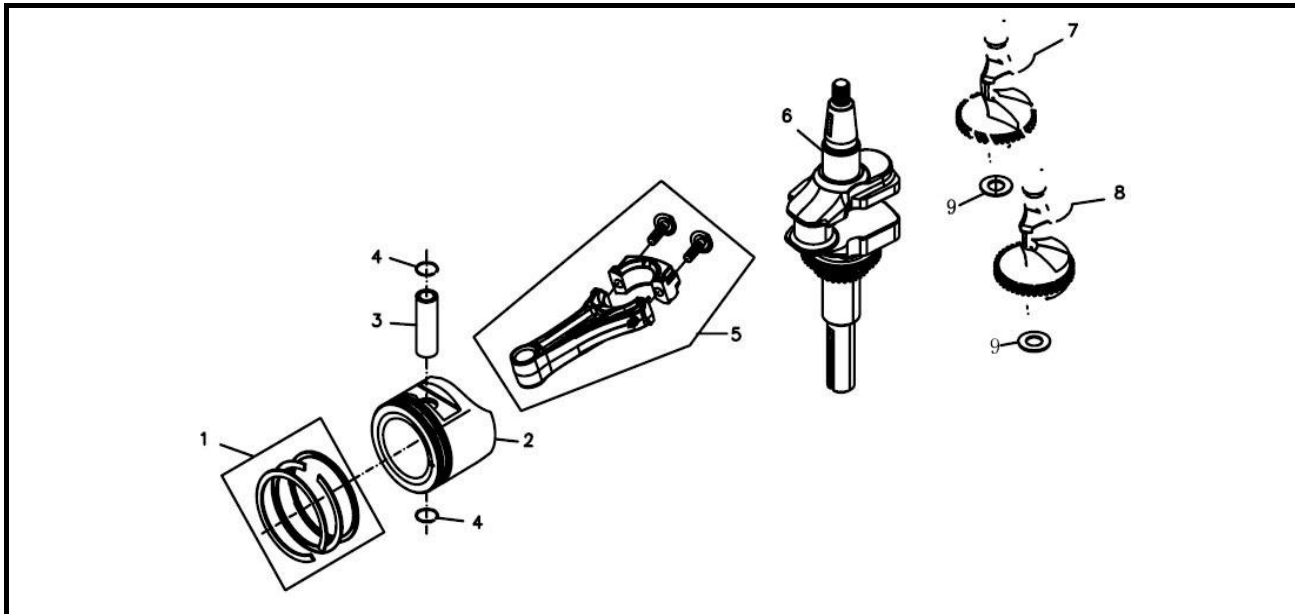

曲轴 (Crankshaft)

序号 No.	零部件件号 Part No.	Description	数量	易损属性
			Reqd. QTY	CONSUMABLE GRADE
1	130070161-0001	Piston ring combination	1	A
2	130030165-0001	Piston	1	A
3	130060034-0001	Piston pin	1	B
4	380560057-0001	Steel cable baffle ring	2	B
5	130150048-0001	Connecting rod	1	B
6	130290102-0001	crankshaft	1	B
7	130450033-0001	Balancing shaft	1	B
8	130450034-0001	Balancing shaft	1	B
9	380450560-0001	Flat washer	2	B

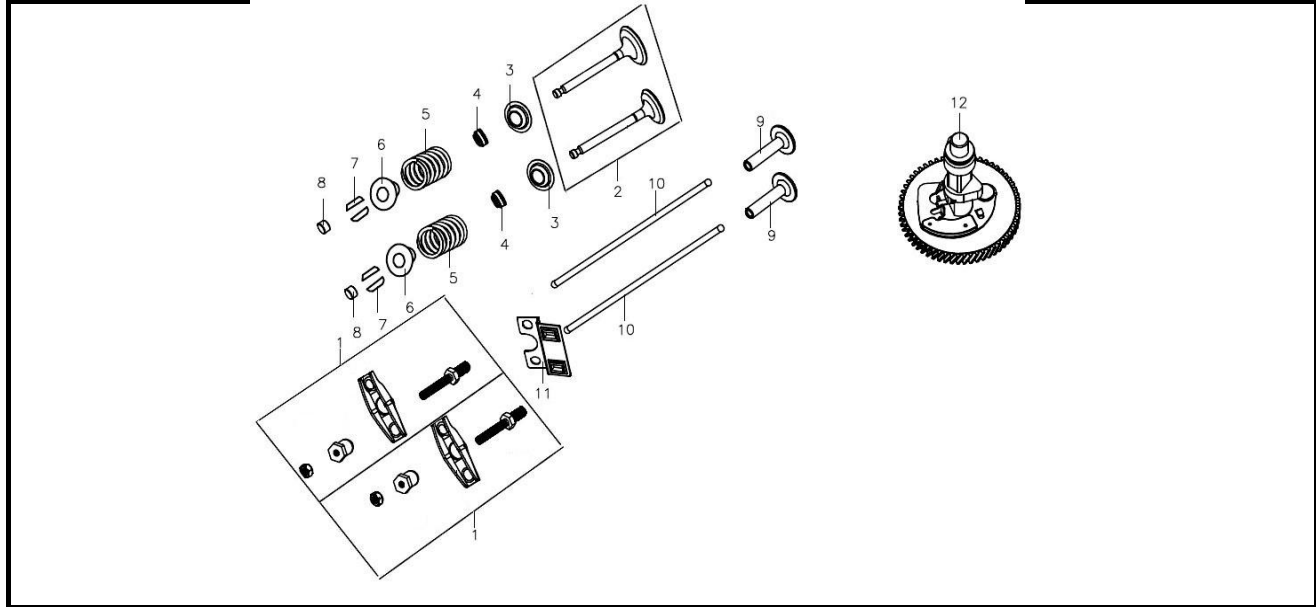

配气机构 (Valve)

序号 No.	零部件件号 Part No.	Description	数量	易损属性
			Reqd. QTY	CONSUMABLE GRADE
1	140450041-0002	Valve rocker combination	2	B
2	500550039-0001	Valve Kit	1	B
3	140360010-0001	Seat, valve spring	2	B
4	140400012-0001	Valve oil seal	2	B
5	140340025-0001	Inner spring of valve	2	B
6	140380021-0001	Retainer, valve spring	2	B
7	140390015-0001	Valve locker	4	B
8	140320002-0001	Valve adjustment cap	2	B
9	140690004-0001	Lifter, Valve	2	B
10	140670030-0001	Push rod	2	B
11	140710011-0001	Plate, push rod guide	1	B
12	140020195-0001	Camshaft assy	1	B

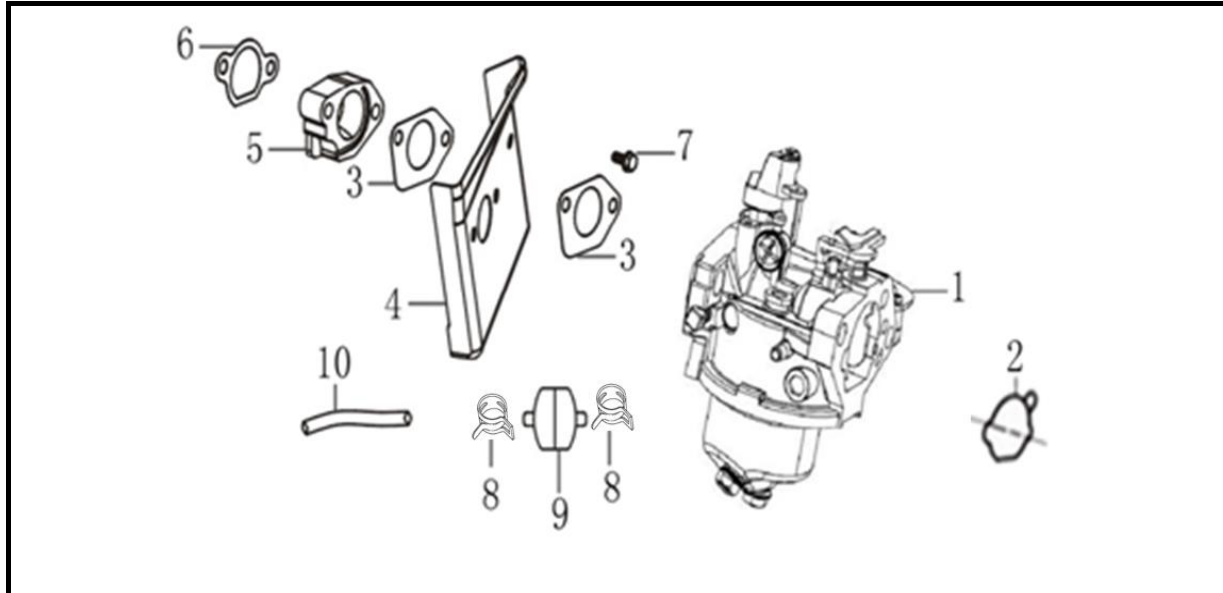

化油器 (Carburetor)

序号 No.	零部件号 Part No.	Description	数量	易损属性
			Reqd. QTY	CONSUMABLE GRADE
1	170022053-0001	Carburetor	1	B
2	170430173-0001	Carburetor gasket	1	A
3	170430099-0001	Carburetor gasket	2	A
4	160190013-0001	air deflector	1	C
5	170440053-0001	Heat insulating pad for carburetor	1	B
6	170430101-0001	Carburetor gasket	1	A
7	380140067-0003	Hexagon bolt with flange	1	C
8	380960120-0004	Clip combination	2	A
9	170010018-0001	Fuel filter	1	A
10	380750431-0001	Oil tube	1	A

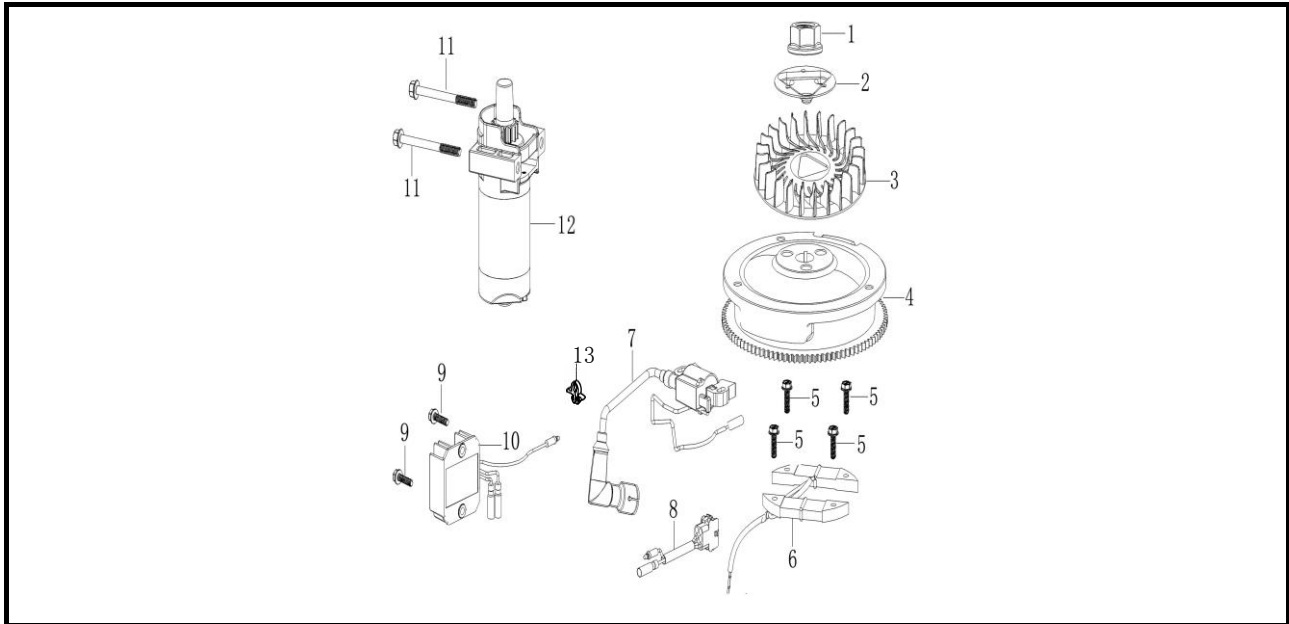

飞轮 (Flywheel)

序号 No.	零部件号 Part No.	Description	数量	易损属性
			Reqd. QTY	CONSUMABLE GRADE
1	380370050-0001	Hexagon nut with flange	1	C
2	193590013-0001	Starting disc	1	C
3	160180037-0001	Impeller	1	B
4	270020229-0001	FLYWHEEL COMP	1	B
5	380140100-0003	Hexagon bolt with flange	4	C
6	270190043-0001	Components of charging current	1	A
7	270920251-0004	COIL ASSY., IGNITION	1	A
8	271280141-0001	Connecting wire	1	A
9	380140209-0001	Hexagon bolt with flange	2	C
10	270880220-0001	RectifierVariable voltage rect	1	A
11	380140364-0001	Hexagon bolt with flange	2	C
12	270360138-0001	Components of starting motor	1	B
13	380930113-0001	Location wire nail	1	A

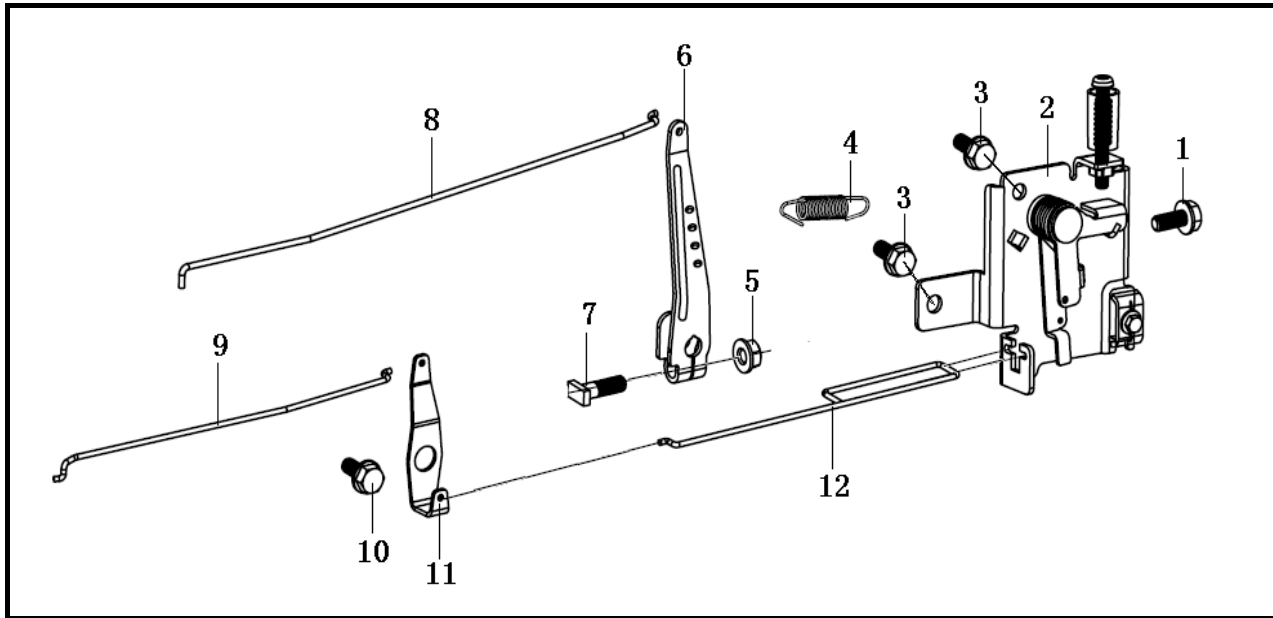

调速机构 (Governor)

序号 No.	零部件件号 Part No.	Description	数量	易损属性
			Reqd. QTY	CONSUMABLE GRADE
1	380140013-0005	Hexagon bolt with flange	1	C
2	171680158-0001	Throttle handle combination	1	B
3	380140209-0001	Hexagon bolt with flange	2	C
4	171600020-0001	Governing spring	1	A
5	380370066-0001	Hexagon nut with flange	1	C
6	171620013-0003	Speed regulating bracket	1	C
7	380250002-0001	Square head set screw with flat	1	C
8	171590013-0001	Throttle rod	1	B
9	171490002-0001	Choke valve bar	1	B
10	380020071-0001	Hexagon shaft shoulder bolt	1	C
11	171480013-0001	Choke valve bracket	1	C
12	171650003-0001	Choke valve pull rod	1	B

