

。(Note vulnerable properties: Refers to the degree of wear and tear in the day-to-day operation of the correct use of this part which according to guide customers reasonable reserves.A for wear and tear easily, B for wear and tear is not easy while C for wear and tear on behalf of the non-basic.The part of A proposal by the highest parts inventory reserves; B for stocking pieces according to the minimum reserves and C try not to make reserves for)

机型Model:LC2P73F-A

版本号: LC/LT - 2019 - A

**气缸头总成 (CYLINDER HEAD ASSY)**

序号 No.	零部件图号 Part No.	Description	数量 Reqd. QTY	易损属性 CONSUMABLE GRADE
1	380140103-0004	Hexagon bolt with flange	8	C
2	120220090-0001	Cylinder head cover assy	2	C
3	120250071-0001	Gasket for cylinder head cover	2	A
4	270960046-0001	Spark plug	2	A
5	380140455-0001	Hexagon bolt with flange	6	C
6	380140456-0001	Hexagon bolt with flange	4	C
7	120080877-0001	Cylinder head	1	B
8	120080878-0001	Cylinder head	1	B
9	120150261-0001	Gasket for cylinder head	2	A
10	380600129-0001	ocation pin	4	C
11	380180109-0001	Stud	4	C
12	180650074-0001	Outlet gasket	2	A

**曲轴箱体 (CRANKCASE)**

序号 No.	零部件图号 Part No.	Description	数量 Reqd. QTY	易损属性 CONSUMABLE GRADE
1	380650337-0001	Oil seal	1	B
2	380741376-0002	Breather tube	1	A
3	380140013-0005	Hexagon bolt with flange	4	C
4	110840048-0001	CAP, BREATHER CHAMBER	1	C
5	110850033-0001	PACKING, BREATHER CHAMBER	1	A
6	662850001-0001	FILTER BLOCK BRACKET	1	C
7	174560005-0001	Filter block	1	A
8	380140067-0003	Hexagon bolt with flange	2	C
9	140250022-0001	Leaf valve	1	B
10	380940779-0001	Cable cleat	1	A
11	380450559-0001	Flat washer	2	C
12	381350004-0001	Pin clip	1	A
13	380650339-0001	Oil seal	1	B

**曲轴箱体 (CRANKCASE)**

序号 No.	零部件图号 Part No.	Description	数量 Reqd. QTY	易损属性 CONSUMABLE GRADE
14	171630013-0001	Speed regulating arm	1	B
15	380140595-0001	Hexagon bolt with flange	2	C
16	270360154-0002	Components of starting motor	1	B
17	160190130-0001	air deflector	1	C
18	380020070-0001	Hexagon shaft shoulder bolt	4	C
19	110810412-0001	Crankcase body	1	B
20	160190129-0001	air deflector	1	C
21	380950400-0001	Pipe clip	1	A

**曲轴箱盖 (CRANKCASE COVER)**

序号 No.	零部件图号 Part No.	Description	数量 Reqd. QTY	易损属性 CONSUMABLE GRADE
1	110820281-0001	Crankcase cover	1	C
2	380650770-0001	Oil seal	1	B
3	380140152-0002	Hexagon bolt with flange	10	C
4	380600123-0001	ocation pin	2	C

5	380640016-0001	Steel ball	1	C
6	381150437-0001	Compression spring	1	A
7	150350046-0002	Oil filter	1	B
8	150840002-0002	Oil filter Mounting bolts	1	C
9	150290044-0001	Engine oil Strainer	1	A
10	150340022-0001	Cover,Oil Strainer	1	C
11	380140013-0005	Hexagon bolt with flange	5	C
12	110830074-0001	Crankcase cover gasket	1	A
13	380840443-0002	Seal ring	1	A
<b>曲轴箱盖 ( CRANKCASE COVER)</b>				
序号 No.	零部件图号 Part No.	Description	数量 Reqd. QTY	易损属性 CONSUMABLE GRADE
14	110950005-0001	Joint of extension bar for bleeding	1	C
15	380960274-0001	Clip combination	2	A
16	380751099-0002	Oil tube	1	A
17	662870001-0001	VALVE-DRAIN, OIL	1	B
18	150040059-0001	Oil pump cover	1	C
19	380840665-0002	Seal ring	1	A
20	150010076-0001	Components of oil pump	1	B
21	171750051-0001	Components of governor gear	1	B
22	110690126-0002	Oil rule combination	1	B
23	380020087-0001	Hexagon shaft shoulder bolt	1	C
24	380140049-0003	Hexagon bolt with flange	2	C
<b>曲轴_活塞 (CRANKSHAFT_PISTON)</b>				
序号 No.	零部件图号 Part No.	Description	数量 Reqd. QTY	易损属性 CONSUMABLE GRADE
1	130070274-0001	Piston ring combination	2	A
2	130030314-0001	Piston	2	A
3	380560078-0001	Steel cable baffle ring	4	B
4	130060085-0001	Piston pin	2	B
5	130150157-0001	Connecting rod	2	B
6	130290666-0001	crankshaft	1	B
<b>配气系统 (ROCKER,CAMSHAFT)</b>				
序号 No.	零部件图号 Part No.	Description	数量 Reqd. QTY	易损属性 CONSUMABLE GRADE
1	140390015-0001	Valve locker	8	B
2	140380021-0001	Retainer, valve spring	4	B
3	140340025-0001	Inner spring of valve	4	B
4	140400012-0001	Valve oil seal	4	B
5	140360010-0001	Seat, valve spring	4	B
6	500550103-0001	Valve Kit	2	B
7	140450035-0002	Valve rocker combination	4	B
8	140710020-0001	Plate, push rod guide	2	B
9	140670070-0001	Push rod	4	B
10	140690017-0001	Lifter, Valve	4	B
11	140020198-0001	Camshaft assy	1	B
<b>化油器 (CARBURETOR)</b>				
序号 No.	零部件图号 Part No.	Description	数量 Reqd. QTY	易损属性 CONSUMABLE GRADE
1	170430106-0001	Carburetor gasket	2	A
2	180420825-0001	Intake pipe	1	C
3	380140100-0003	Hexagon bolt with flange	4	C
4	380180093-0001	Stud	4	C
5	170430227-0001	Carburetor gasket	2	A
6	170440120-0001	Heat insulating pad for carburetor	1	B
7	170022197-0002	Carburetor	1	B
8	170430184-0001	Carburetor gasket	1	A
9	173090003-0001	Locker of choke valve pull rob	1	A

10	170470022-0001	Gasoline pump bracket	1	C
11	170010045-0001	Fuel filter	1	A
12	380960287-0001	Clip combination	6	A
<b>化油器 (CARBURETOR)</b>				
序号	零部件图号	Description	数量	易损属性
No.	Part No.		Reqd. QTY	CONSUMABLE GRADE
13	380751189-0001	Oil tube	1	A
14	170460026-0001	Gasoline pump	1	B
15	380140103-0004	Hexagon bolt with flange	2	C
16	380020070-0001	Hexagon shaft shoulder bolt	2	C
17	380741377-0002	Breather tube	1	A
18	380750742-0001	Oil tube	1	A
19	380770339-0002	PROTECTIVE SLEEVE	1	A
<b>磁电机转子部分 (FLYWHEEL)</b>				
序号	零部件图号	Description	数量	易损属性
No.	Part No.		Reqd. QTY	CONSUMABLE GRADE
1	270190061-0002	Components of charging current armature	1	A
2	380190039-0005	Socket head screw	4	C
3	270020439-0001	FLYWHEEL COMP	1	B
4	380450702-0001	Flat washer	1	C
5	380140457-0001	Hexagon bolt with flange	1	C
6	160180048-0001	Impeller	1	B
7	160850010-0001	Impeller cover	1	B
8	380140769-0001	Hexagon bolt with flange	4	C
9	380140103-0004	Hexagon bolt with flange	4	C
10	270920452-0002	COIL ASSY., IGNITION	1	A
11	270920453-0002	COIL ASSY., IGNITION	1	A
12	380140013-0005	Hexagon bolt with flange	2	C
13	380140040-0005	Hexagon bolt with flange	1	C
<b>磁电机转子部分 (FLYWHEEL)</b>				
序号	零部件图号	Description	数量	易损属性
No.	Part No.		Reqd. QTY	CONSUMABLE GRADE
14	270880264-0002	RectifierVariable voltage rectifier	1	A
15	380900062-0001	Strap	1	A
16	271280184-0002	Connecting wire	1	A
17	380900061-0002	Strap	2	A
<b>风扇罩 (FAN COVER ASSY)</b>				
序号	零部件图号	Description	数量	易损属性
No.	Part No.		Reqd. QTY	CONSUMABLE GRADE
1	160210195-0001	Fan cover comp.	1	B
2	380020202-0001	Hexagon shaft shoulder bolt	2	C
3	380020087-0001	Hexagon shaft shoulder bolt	1	C
<b>调速控制 (CONTROL)</b>				
序号	零部件图号	Description	数量	易损属性
No.	Part No.		Reqd. QTY	CONSUMABLE GRADE
1	171600155-0001	Governing spring	1	A
2	171620062-0002	Speed regulating bracket	1	C
3	171680200-0001	Throttle handle combination	1	B
4	171610040-0001	throttle return spring	1	A
5	173090003-0001	Locker of choke valve pull rob	1	A
6	171590040-0001	Throttle rod	1	B
7	380140013-0005	Hexagon bolt with flange	2	C
8	381140626-0001	Tension spring	1	A
9	171650059-0001	Choke valve pull rod	1	B
<b>空滤器 (AIR CLEANER)</b>				
序号	零部件图号	Description	数量	易损属性
No.	Part No.		Reqd. QTY	CONSUMABLE GRADE
1	180280170-0001	Air filter seat	1	B

2	381000305-0002	Caulking	1	A
3	380370066-0001	Hexagon nut with flange	4	C
4	180100123-0001	Air filter element combination	1	A

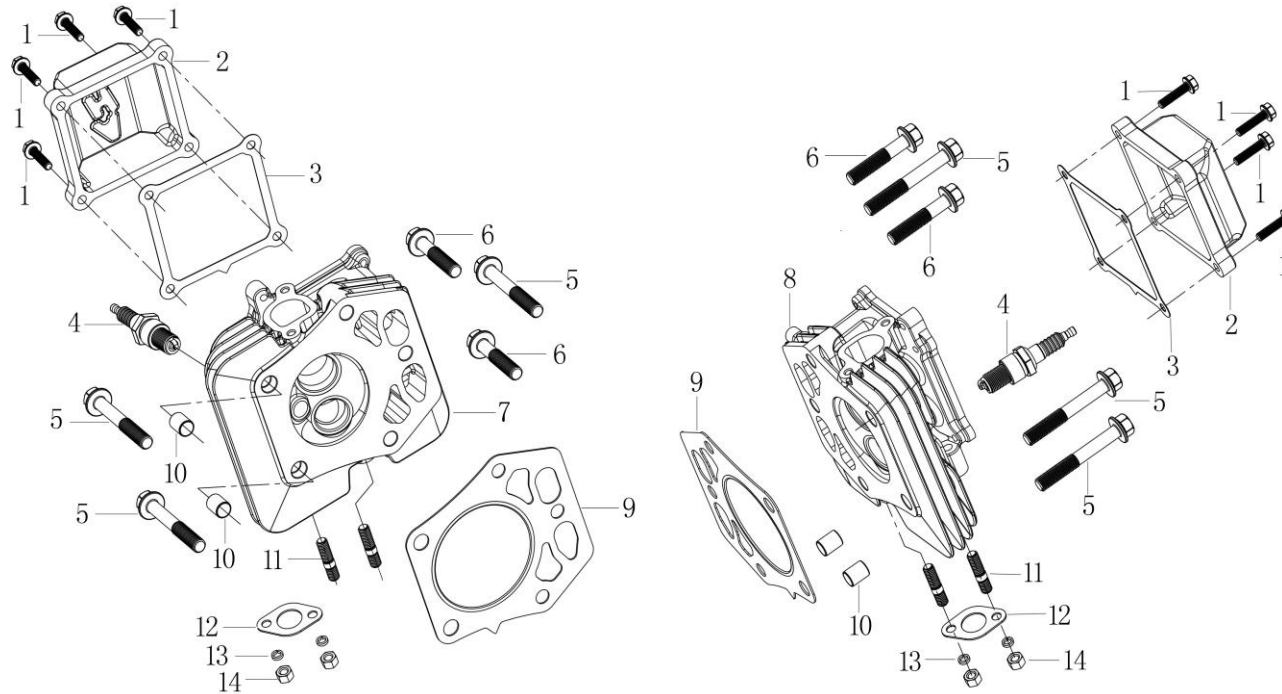

气缸头总成 (CYLINDER HEAD ASSY)				
序号	零部件图号	Description	数量	易损属性
No.	Part No.		Reqd. QTY	CONSUMABLE GRADE
1	380140103-0004	Hexagon bolt with flange	8	C
2	120220090-0001	Cylinder head cover assy	2	C
3	120250071-0001	Gasket for cylinder head cover	2	A
4	270960046-0001	Spark plug	2	A
5	380140455-0001	Hexagon bolt with flange	6	C
6	380140456-0001	Hexagon bolt with flange	4	C
7	120080877-0001	Cylinder head	1	B
8	120080878-0001	Cylinder head	1	B
9	120150261-0001	Gasket for cylinder head	2	A
10	380600129-0001	ocation pin	4	C
11	380180109-0001	Stud	4	C
12	180650074-0001	Outlet gasket	2	A
13	380460001-0006	Elastic washer	4	B
14	380340005-0005	Hexagon nut	4	C

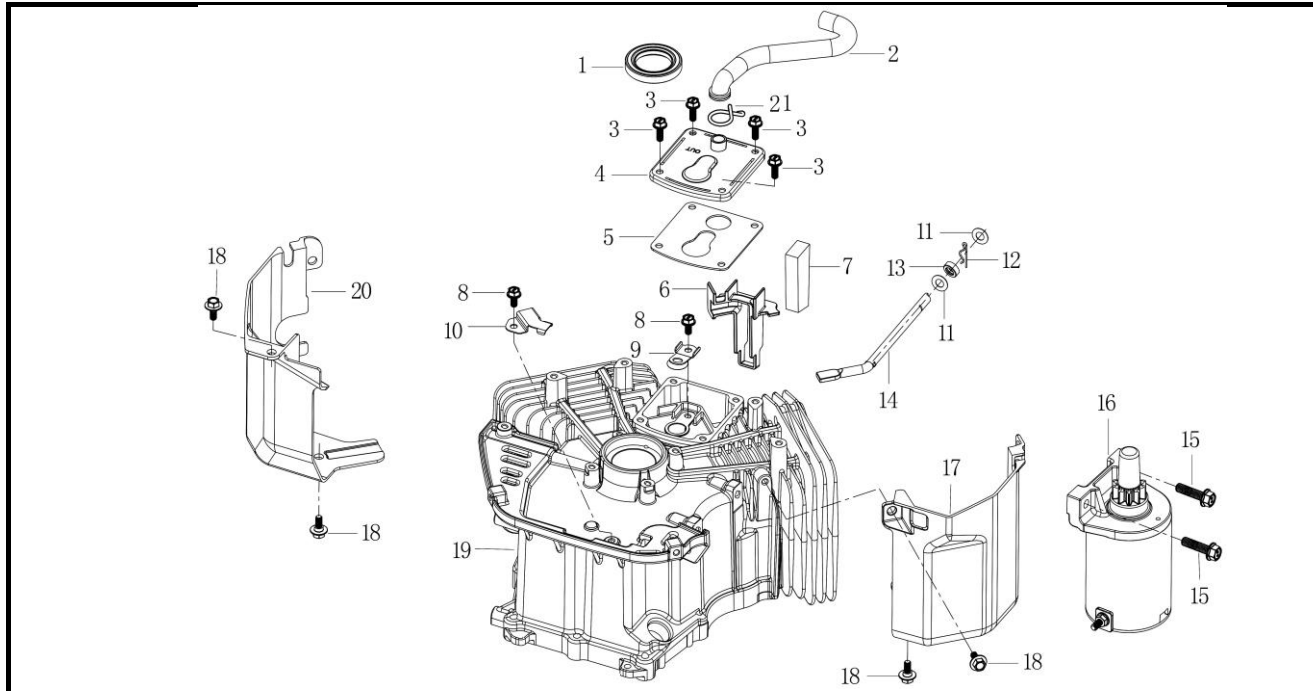

曲轴箱体 (CRANKCASE)

序号 No.	零部件图号 Part No.	Description	数量 Reqd. QTY	易损属性 CONSUMABLE GRADE
1	380650337-0001	Oil seal	1	B
2	380741376-0002	Breather tube	1	A
3	380140013-0005	Hexagon bolt with flange	4	C
4	110840048-0001	CAP, BREATHER CHAMBER	1	C
5	110850033-0001	PACKING, BREATHER CHAMBER	1	A
6	662850001-0001	FILTER BLOCK BRACKET	1	C
7	174560005-0001	Filter block	1	A
8	380140067-0003	Hexagon bolt with flange	2	C
9	140250022-0001	Leaf valve	1	B
10	380940779-0001	Cable cleat	1	A
11	380450559-0001	Flat washer	2	C
12	381350004-0001	Pin clip	1	A
13	380650339-0001	Oil seal	1	B

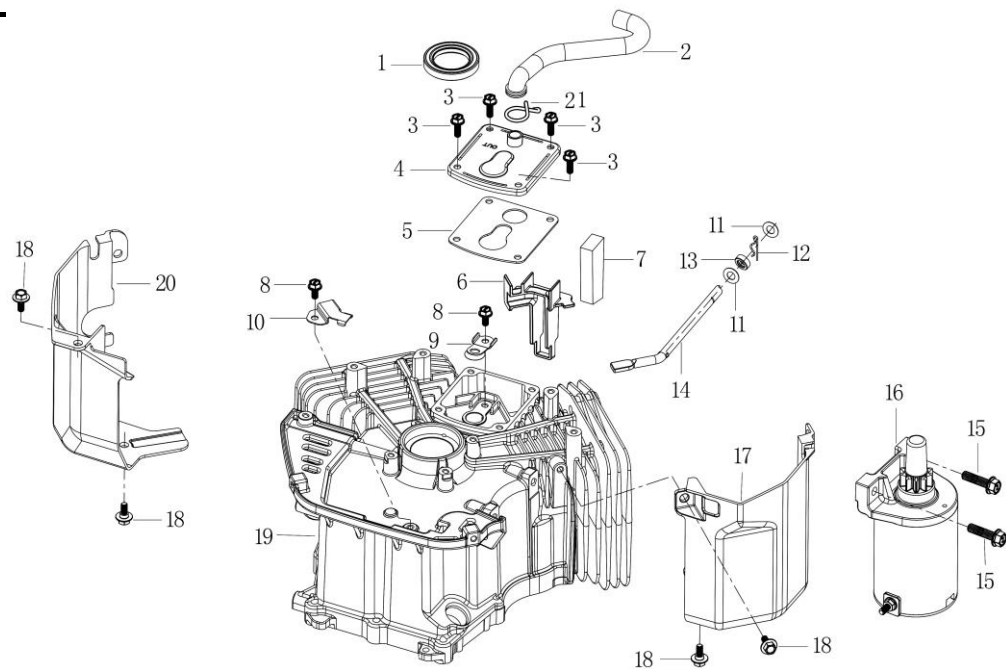

曲轴箱体 (CRANKCASE)

序号 No.	零部件图号 Part No.	Description	数量 Reqd. QTY	易损属性 CONSUMABLE GRADE
14	171630013-0001	Speed regulating arm	1	B
15	380140595-0001	Hexagon bolt with flange	2	C
16	270360154-0002	Components of starting motor	1	B
17	160190130-0001	air deflector	1	C
18	380020070-0001	Hexagon shaft shoulder bolt	4	C
19	110810412-0001	Crankcase body	1	B
20	160190129-0001	air deflector	1	C
21	380950400-0001	Pipe clip	1	A

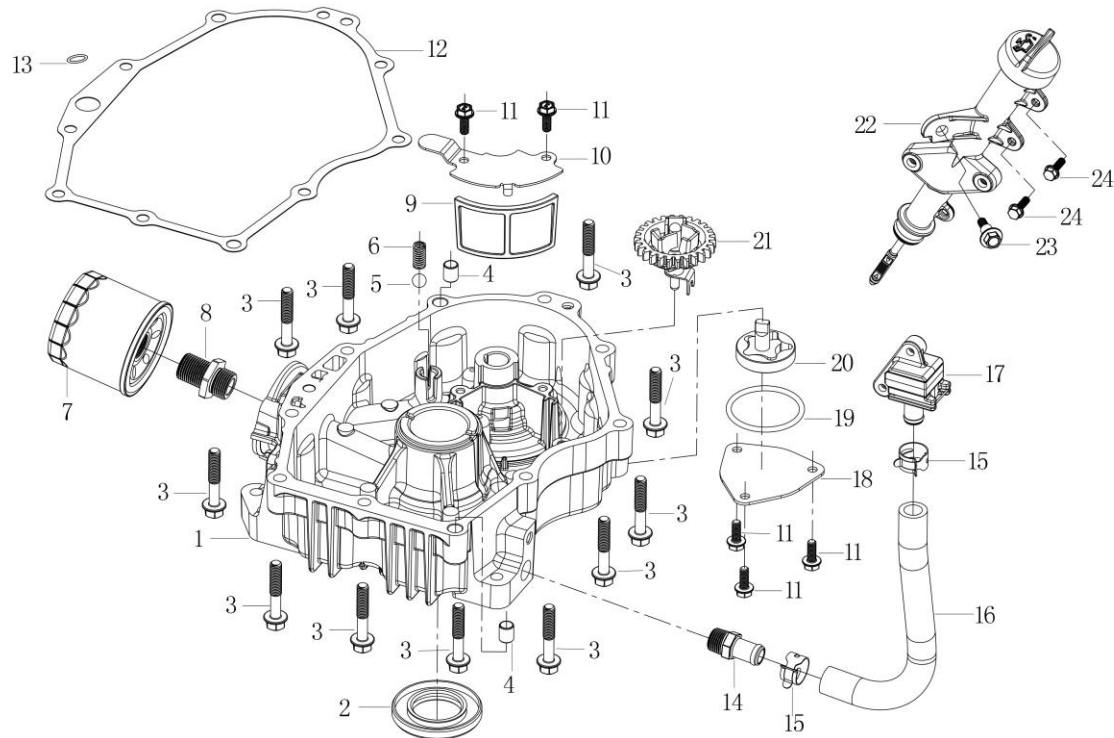

曲轴箱盖 (CRANKCASE COVER)

序号 No.	零部件图号 Part No.	Description	数量 Reqd. QTY	易损属性 CONSUMABLE GRADE
1	110820281-0001	Crankcase cover	1	C
2	380650770-0001	Oil seal	1	B
3	380140152-0002	Hexagon bolt with flange	10	C
4	380600123-0001	ocation pin	2	C
5	380640016-0001	Steel ball	1	C
6	381150437-0001	Compression spring	1	A
7	150350046-0002	Oil filter	1	B
8	150840002-0002	Oil filter Mounting bolts	1	C
9	150290044-0001	Engine oil Strainer	1	A
10	150340022-0001	Cover,Oil Strainer	1	C
11	380140013-0005	Hexagon bolt with flange	5	C
12	110830074-0001	Crankcase cover gasket	1	A
13	380840443-0002	Seal ring	1	A

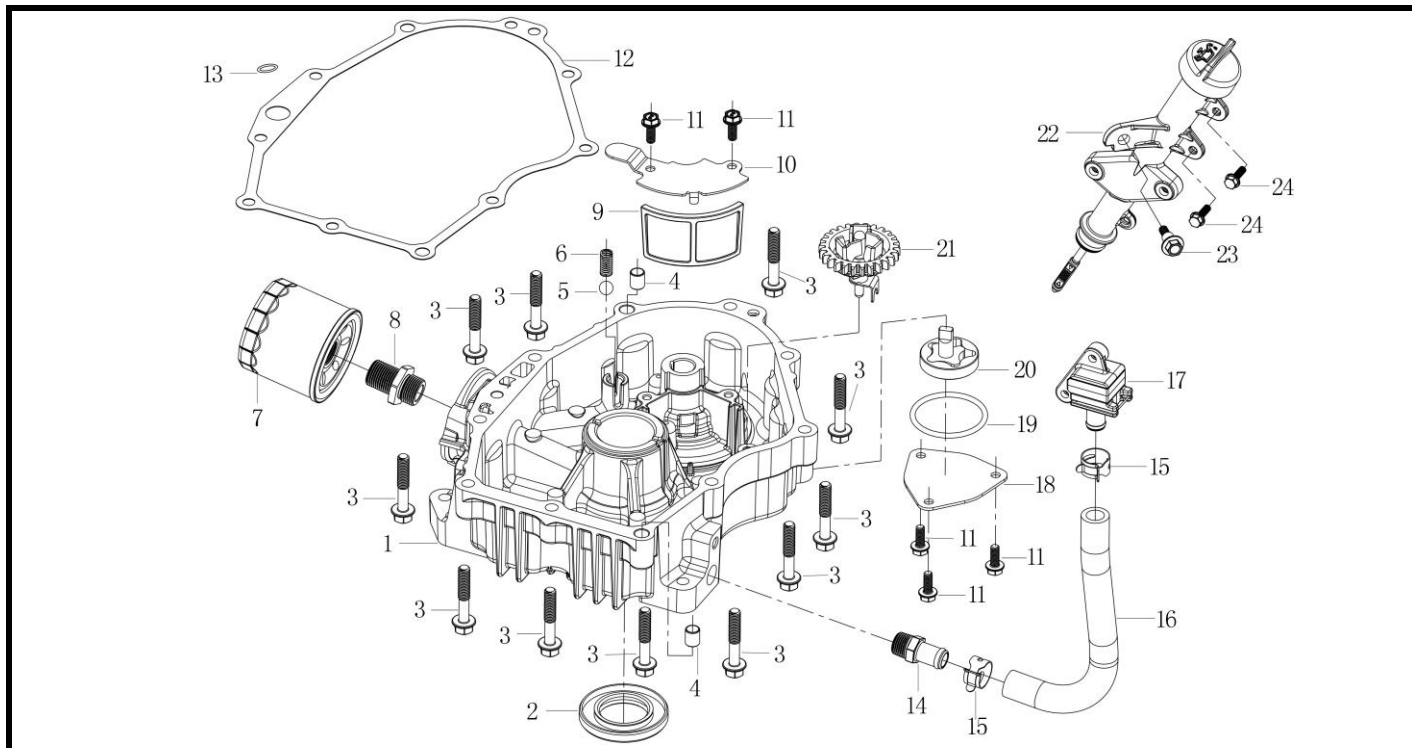

**曲轴箱盖 ( CRANKCASE COVER)**

序号 No.	零部件图号 Part No.	Description	数量 Reqd. QTY	易损属性 CONSUMABLE GRADE
14	110950005-0001	Joint or extension bar for	1	C
15	380960274-0001	Clip combination	2	A
16	380751099-0002	Oil tube	1	A
17	662870001-0001	VALVE-DRAIN, OIL	1	B
18	150040059-0001	Oil pump cover	1	C
19	380840665-0002	Seal ring	1	A
20	150010076-0001	Components of oil pump	1	B
21	171750051-0001	Components of governor gear	1	B
22	110690126-0002	Oil rule combination	1	B
23	380020087-0001	Hexagon shaft shoulder bolt	1	C
24	380140049-0003	Hexagon bolt with flange	2	C



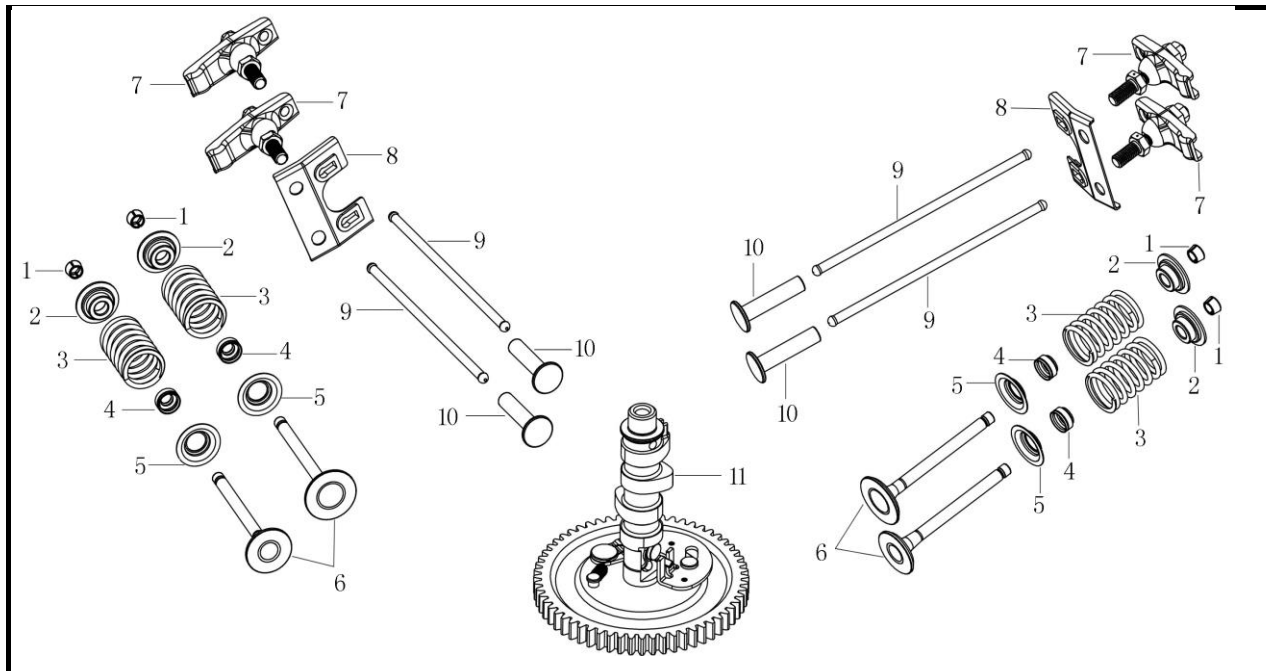

配气系统 (ROCKER,CAMSHAFT)

序号 No.	零部件图号 Part No.	Description	数量 Reqd. QTY	易损属性 CONSUMABLE GRADE
1	140390015-0001	Valve locker	8	B
2	140380021-0001	Retainer, valve spring	4	B
3	140340025-0001	Inner spring of valve	4	B
4	140400012-0001	Valve oil seal	4	B
5	140360010-0001	Seat, valve spring	4	B
6	500550103-0001	Valve Kit	2	B
7	140450035-0002	Valve rocker combination	4	B
8	140710020-0001	Plate, push rod guide	2	B
9	140670070-0001	Push rod	4	B
10	140690017-0001	Lifter, Valve	4	B
11	140020198-0001	Camshaft assy	1	B

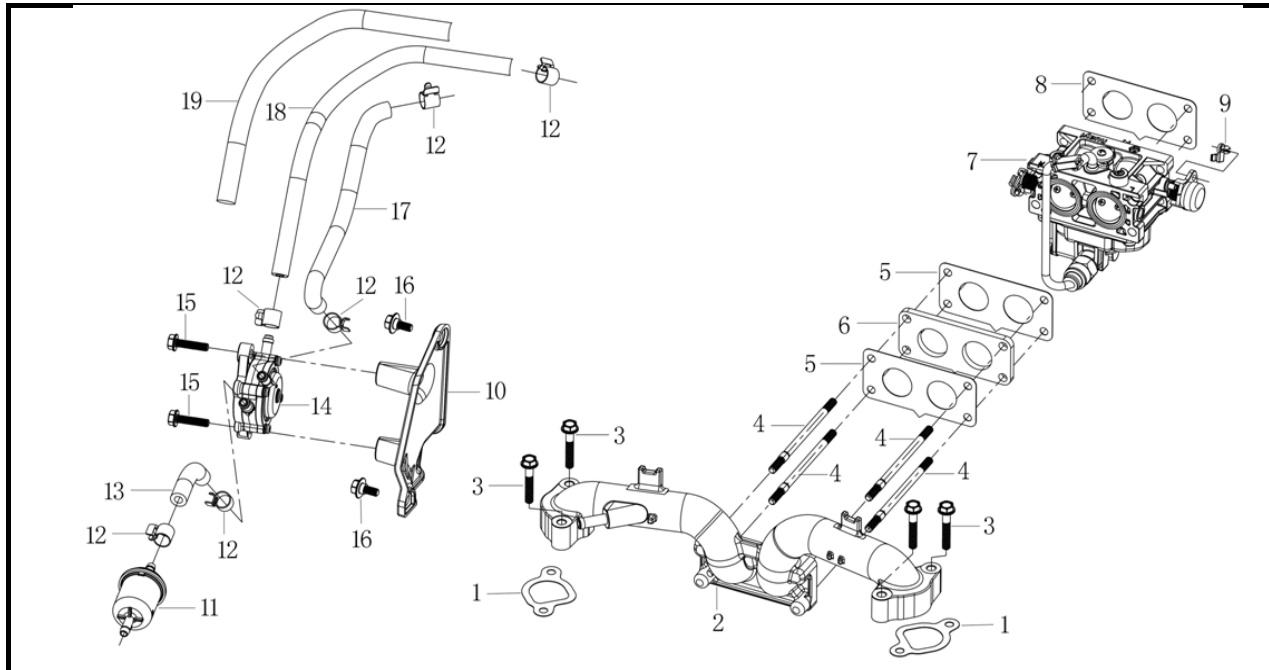

化油器 (CARBURETOR)

序号 No.	零部件图号 Part No.	Description	数量 Reqd. QTY	易损属性 CONSUMABLE GRADE
1	170430106-0001	Carburetor gasket	2	A
2	180420825-0001	Intake pipe	1	C
3	380140100-0003	Hexagon bolt with flange	4	C
4	380180093-0001	Stud	4	C
5	170430227-0001	Carburetor gasket	2	A
6	170440120-0001	Heat insulating pad for carburetor	1	B
7	170022197-0002	Carburetor	1	B
8	170430184-0001	Carburetor gasket	1	A
9	173090003-0001	Locker of choke valve pull rod	1	A
10	170470022-0001	Gasoline pump bracket	1	C
11	170010045-0001	Fuel filter	1	A
12	380960287-0001	Clip combination	6	A

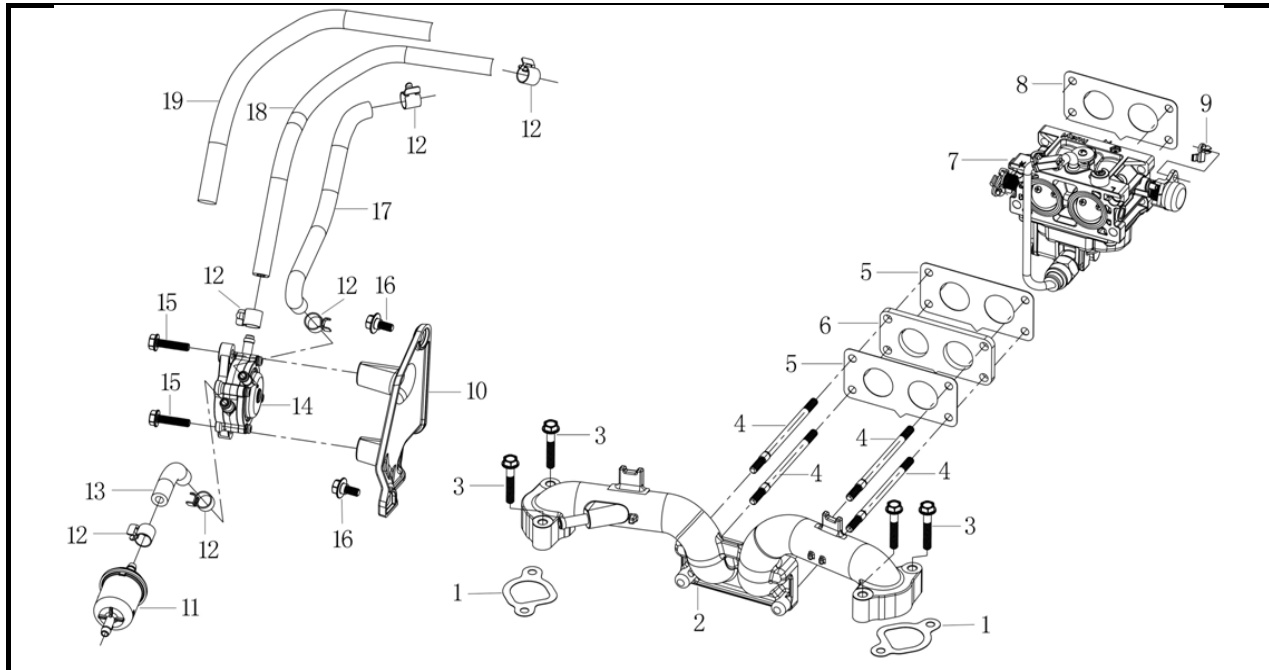

化油器 (CARBURETOR)

序号 No.	零部件图号 Part No.	Description	数量 Reqd. QTY	易损属性 CONSUMABLE GRADE
13	380751189-0001	Oil tube	1	A
14	170460026-0001	Gasoline pump	1	B
15	380140103-0004	Hexagon bolt with flange	2	C
16	380020070-0001	Hexagon shaft shoulder bolt	2	C
17	380741377-0002	Breather tube	1	A
18	380750742-0001	Oil tube	1	A
19	380770339-0002	PROTECTIVE SLEEVE	1	A

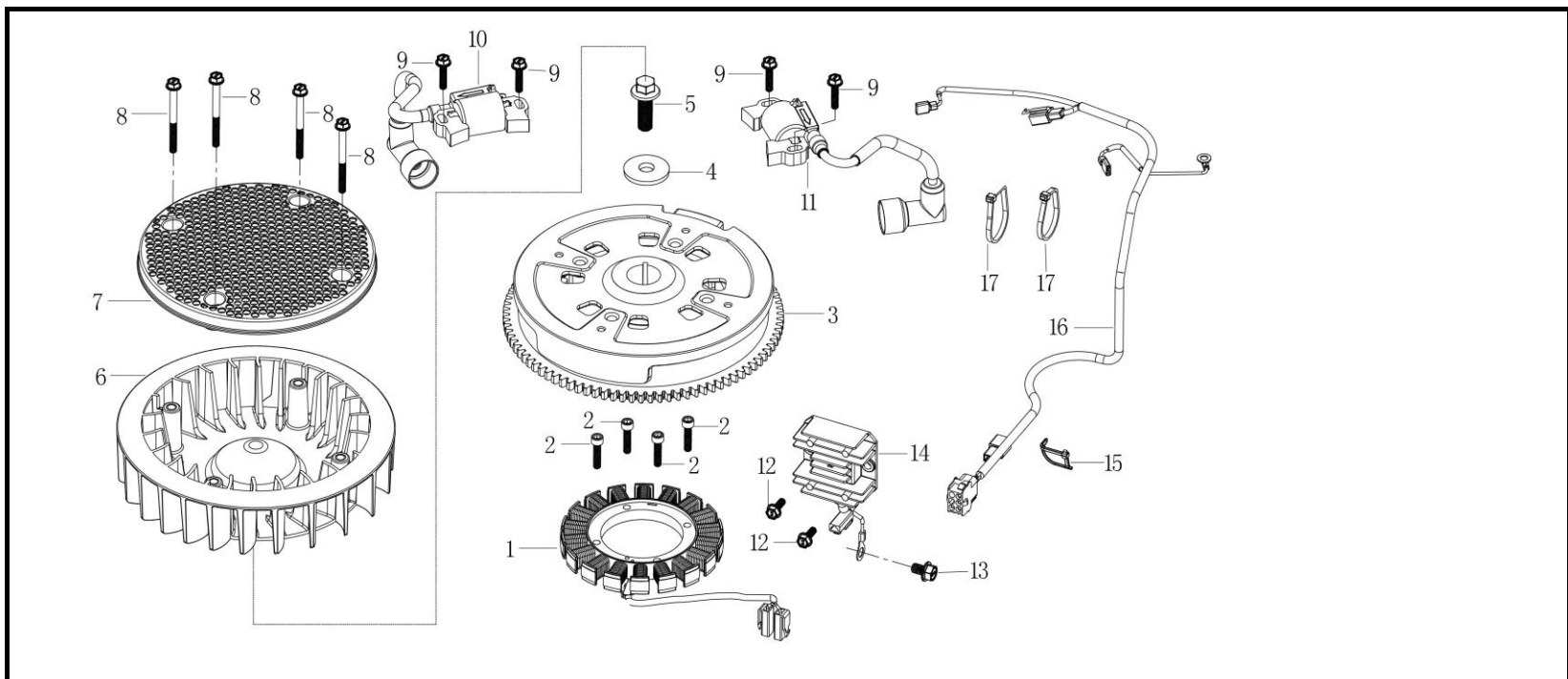

磁电机转子部分 (FLYWHEEL)

序号 No.	零部件图号 Part No.	Description	数量 Reqd. QTY	易损属性 CONSUMABLE GRADE
1	270190061-0002	Components of charging current armature	1	A
2	380190039-0005	Socket head screw	4	C
3	270020439-0001	FLYWHEEL COMP	1	B
4	380450702-0001	Flat washer	1	C
5	380140457-0001	Hexagon bolt with flange	1	C
6	160180048-0001	Impeller	1	B
7	160850010-0001	Impeller cover	1	B
8	380140769-0001	Hexagon bolt with flange	4	C
9	380140103-0004	Hexagon bolt with flange	4	C
10	270920452-0002	COIL ASSY., IGNNTION	1	A
11	270920453-0002	COIL ASSY., IGNNTION	1	A
12	380140013-0005	Hexagon bolt with flange	2	C
13	380140040-0005	Hexagon bolt with flange	1	C





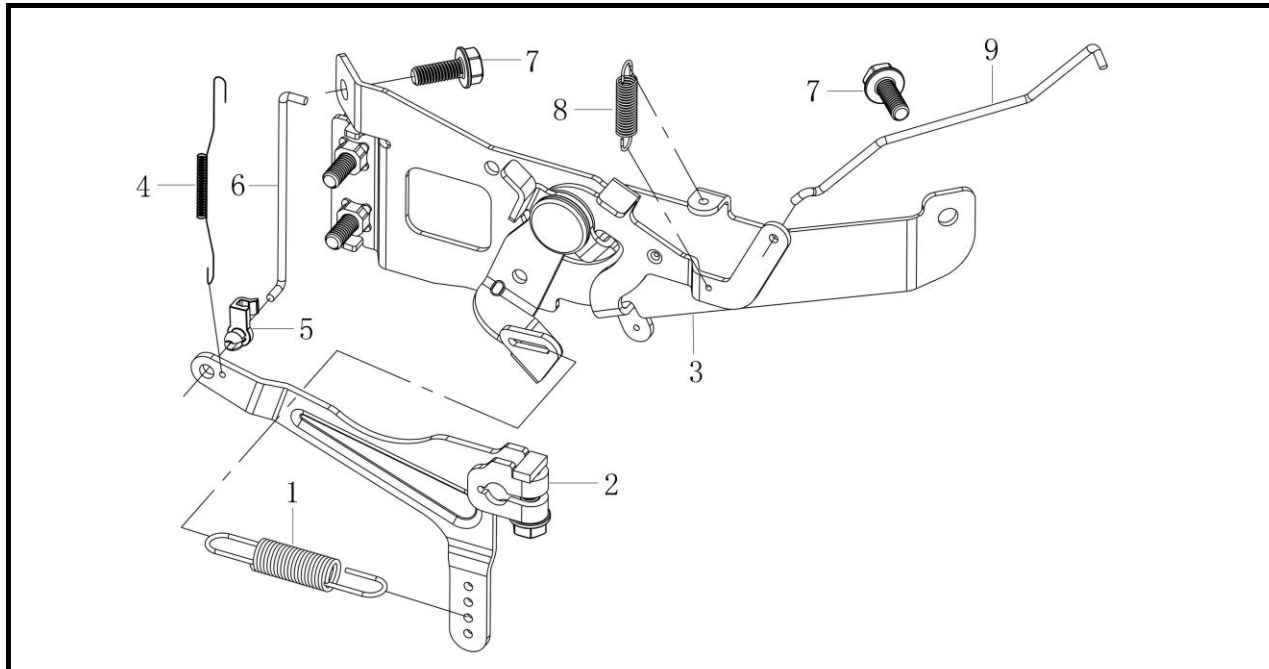

调速控制 ( CONTROL )

序号 No.	零部件图号 Part No.	Description	数量 Reqd. QTY	易损属性 CONSUMABLE GRADE
1	171600155-0001	Governing spring	1	A
2	171620062-0002	Speed regulating bracket	1	C
3	171680200-0001	Throttle handle combination	1	B
4	171610040-0001	throttle return spring	1	A
5	173090003-0001	Locker of choke valve pull rob	1	A
6	171590040-0001	Throttle rod	1	B
7	380140013-0005	Hexagon bolt with flange	2	C
8	381140626-0001	Tension spring	1	A
9	171650059-0001	Choke valve pull rod	1	B

